



CATALOGO

CHIAVI RESIDENZIALI

2023

CIAT
SERVICE
AUTOMOTIVE TECHNOLOGY



www.ciat-service.it

CHIAVI COLORATE



SERIE HAPPY CILINDRO

MODELLI DISPONIBILI

| | | | | |
|----------|---------|---------|---------|--------|
| CI205DXH | GI1H | PR4SIMH | UNQ5SXH | WK5DXH |
| CI5DXH | ME4DXRH | PR5DXH | VI4DXRH | WA5SXH |
| FA4SIMH | OM5DXRH | PR5SIMH | VI5DXH | |
| FA5SIMH | PR4DXH | UNQ5DXH | VI5DXRH | |

CONFEZIONE PZ 100
COLORI ASSORTITI
 Su richiesta si esegue qualsiasi
 tipo di chiave colorata.

SERIE HAPPY DOPPIA MAPPA

MODELLI DISPONIBILI

| | | | | |
|-------|--------|--------|------|-------|
| ATR1H | CR25H | CS4H | IS1H | MT4H |
| ATR3H | CR28H | CSV15H | IS3H | MT8H |
| ATR9H | CRP21H | CSV16H | JW6H | MT21H |
| CE16H | CS1H | ID1H | MT3H | SM3H |

CONFEZIONE PZ 25
COLORI ASSORTITI
 Su richiesta si esegue qualsiasi
 tipo di chiave colorata.

SERIE SIRIO

MODELLI DISPONIBILI

| | |
|--------|---------|
| UN5DXS | UN5DXRS |
| UN5SXS | UN5SXR5 |
| UN4DXS | CO6DXS |
| UN4SXS | |

CONFEZIONE PZ 100
COLORI ASSORTITI
CONFEZIONE PZ 50
PER COLORE

SERIE JOY

MODELLI DISPONIBILI

| | |
|---------|--------|
| UN5DXJ | UN4DXJ |
| UN5DXRJ | UN6DXJ |
| UN5SXJ | UN4SXJ |
| UN5SXRJ | CI5DXJ |

CONFEZIONE PZ 100
COLORI ASSORTITI

CHIAVI CILINDRO





AGB

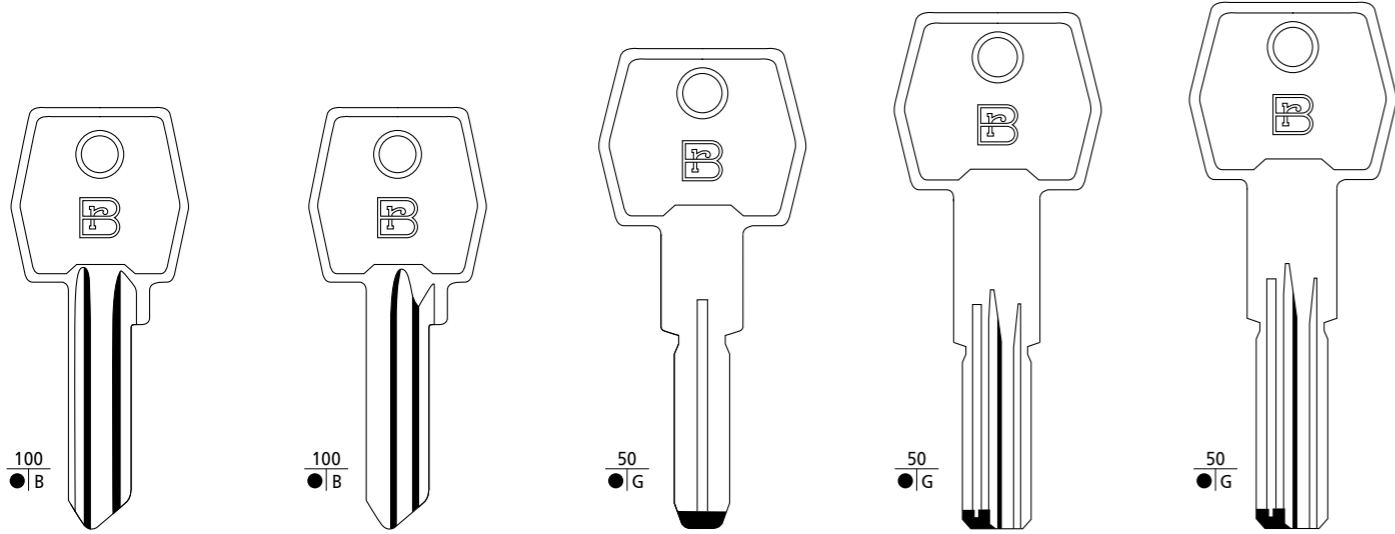

AG5DX
S. AGB1
E. AGB5D
K. AGB5D

AG5SX
S. AGB1R
E. AGB5S
K. AGB5S

AG1
S. AGB5
E. AGB6
K. AGB1

AG2
S. AGB9
E. AGB10
K. AGB9

AG3
S. AGB8
E. AGB9
K. AGB8

ATRA

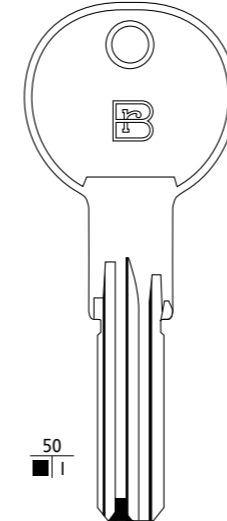

AT20
S. IE26
E. AT12
K. ISE17

BIERRE (BECCARINI)

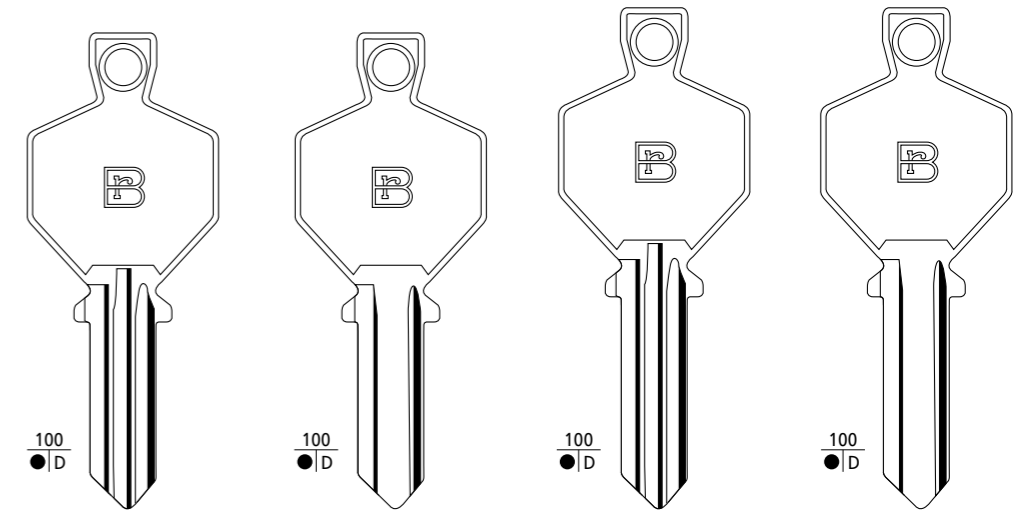

BR4DX
S. BN1
E. BE4

BR4SX
S. BN1R

BR5DX
S. BN2

BR5SX
S. BN2R

BETA

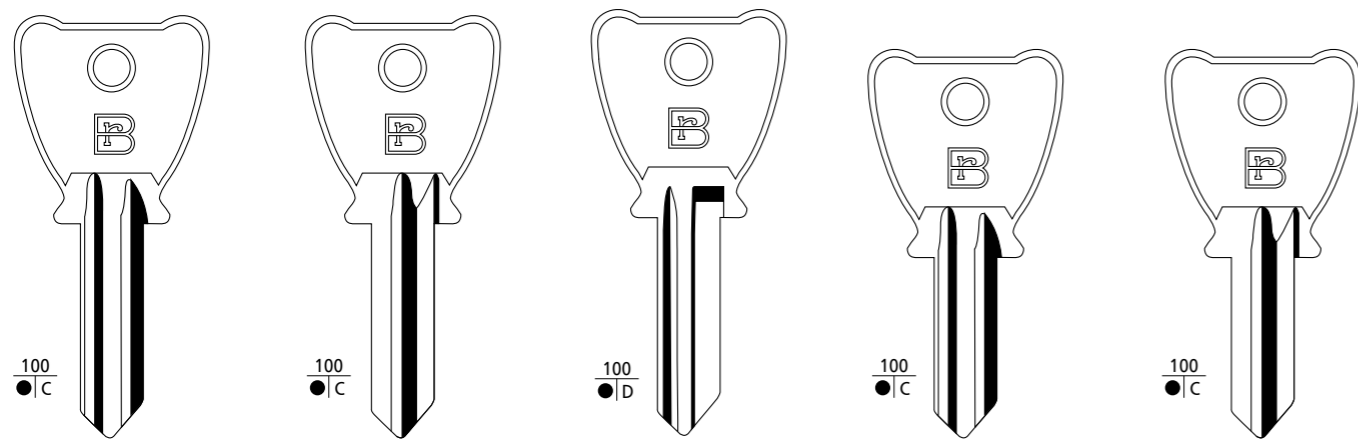

BE5DX
S. BE202
E. B5D
K. BE5D

BE5SX
S. BE203
E. B5S
K. BE5S

BE5SIM
S. BE3
E. B6
K. BE5SM

BE4DX
S. BE200
E. B4D
K. BE4D

BE4SX
S. BE201
E. B4S
K. BE4S

BRICARD

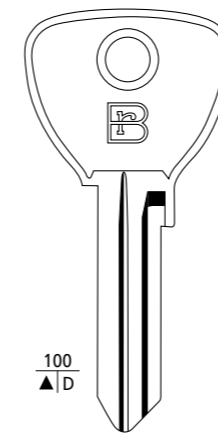

BC1
S. BD9R
E. BD11R
K. BD9S

CAB

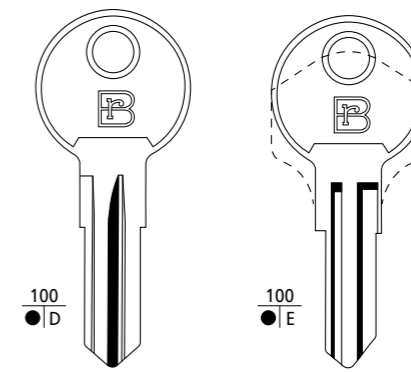

CAB1
S. CAB2R
E. CAB2R
K. CAB2S

CAB2
S. CAB1
E. CAB1
K. CAB1

CAS

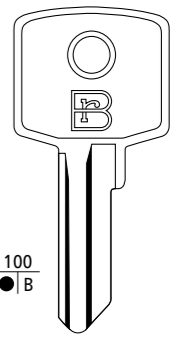

CA2
S. CIS2
E. CIS2
K. CAS2PD



CISA

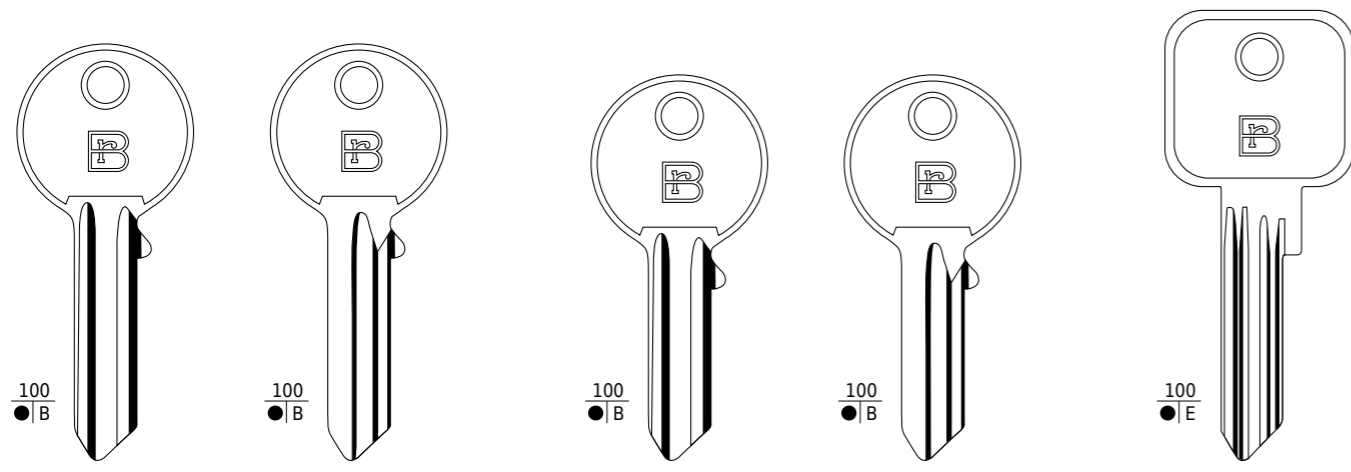

CI5DX
100
●/B
S. CS206
E. C5D
K. CA5D

CI5SX
100
●/B
S. CS207
E. C5S
K. CA5S

CI4DX
100
●/B
S. CS204
E. C4D
K. CA4D

CI4SX
100
●/B
S. CS205
E. C4S
K. CA4S

CI17
100
●/E
S. CS17
E. C17
K. CA50D

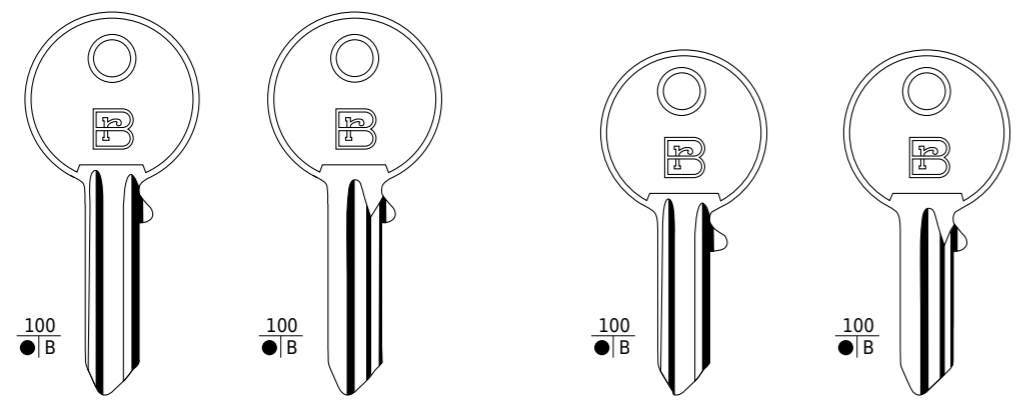

CI5DXR
100
●/B
S. CS7
E. C5PD
K. CA5PD

CI5SXR
100
●/B
S. CS7R
E. C5PS
K. CA5PS

CI4DXR
100
●/B
S. CS6
E. C4PD
K. CA4PD

CI4SXR
100
●/B
S. CS6R
E. C4PS
K. CA4PS

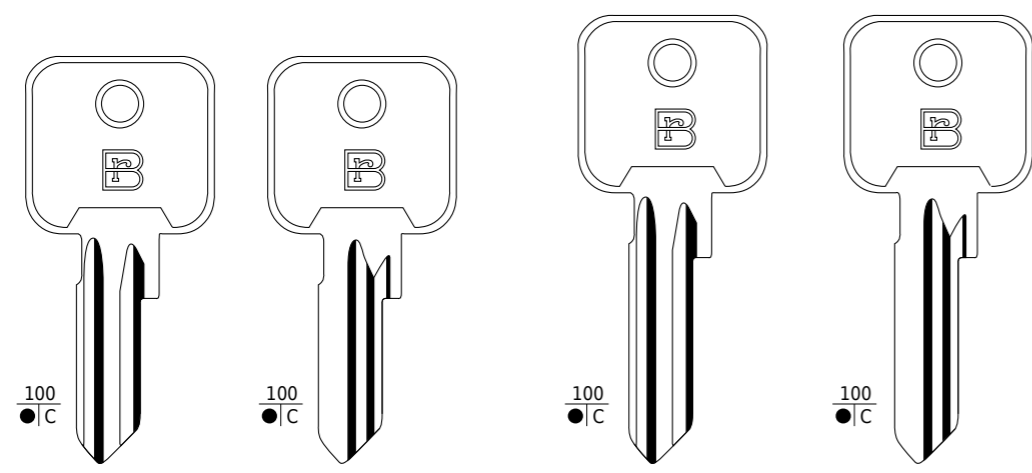

CI104DX
100
●/C
S. CS47
E. C4DQ
K. CA17

CI104SX
100
●/C
S. CS47R
E. C4SQ
K. CA17S

CI105DX
100
●/C
S. CS46
E. C5DQ
K. CA16

CI105SX
100
●/C
S. CS46R
E. C5SQ
K. CA16S

CISA

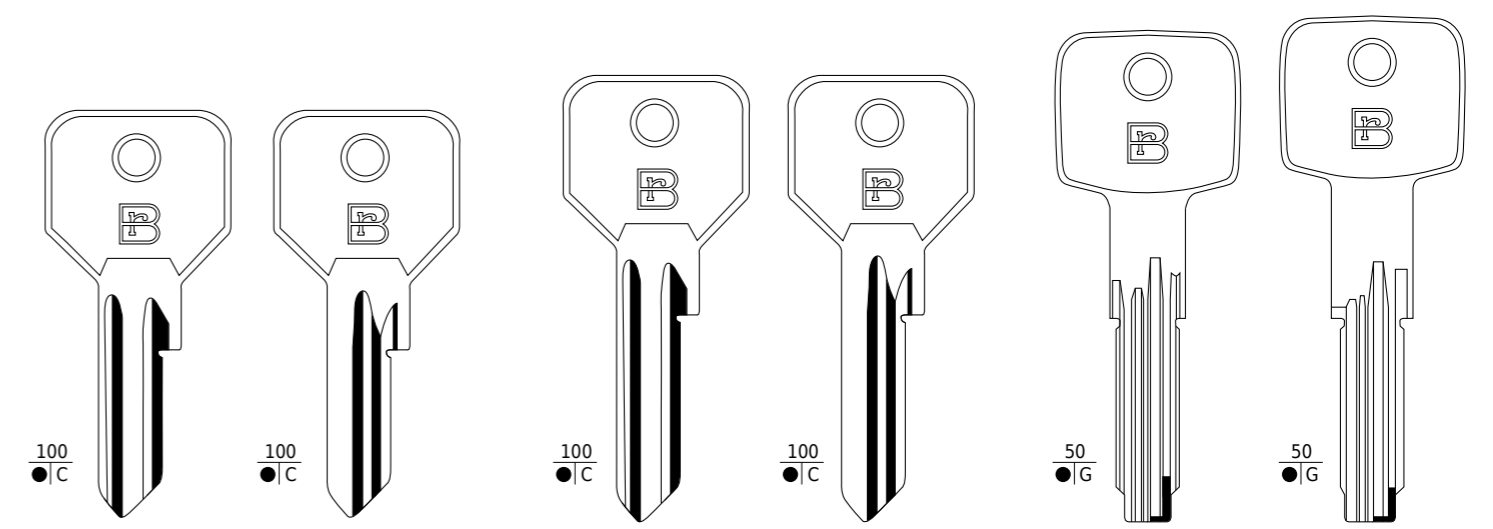

CI204DX
100
●/C
S. CS120
E. C4DE
K. CA40D

CI204SX
100
●/C
S. CS120R
E. C4SE
K. CA40S

CI205DX
100
●/C
S. CS119
E. C5DE
K. CA41D

CI205SX
100
●/C
S. CS119R
E. C5SE
K. CA41S

CI30 ASTRAL
50
●/G
S. CS62
E. C24L
K. CA62

CI31 ASIX
50
●/G
S. CS70/CS171
E. C25L
K. CA87

CISA

CILA - GENTILI

CITY

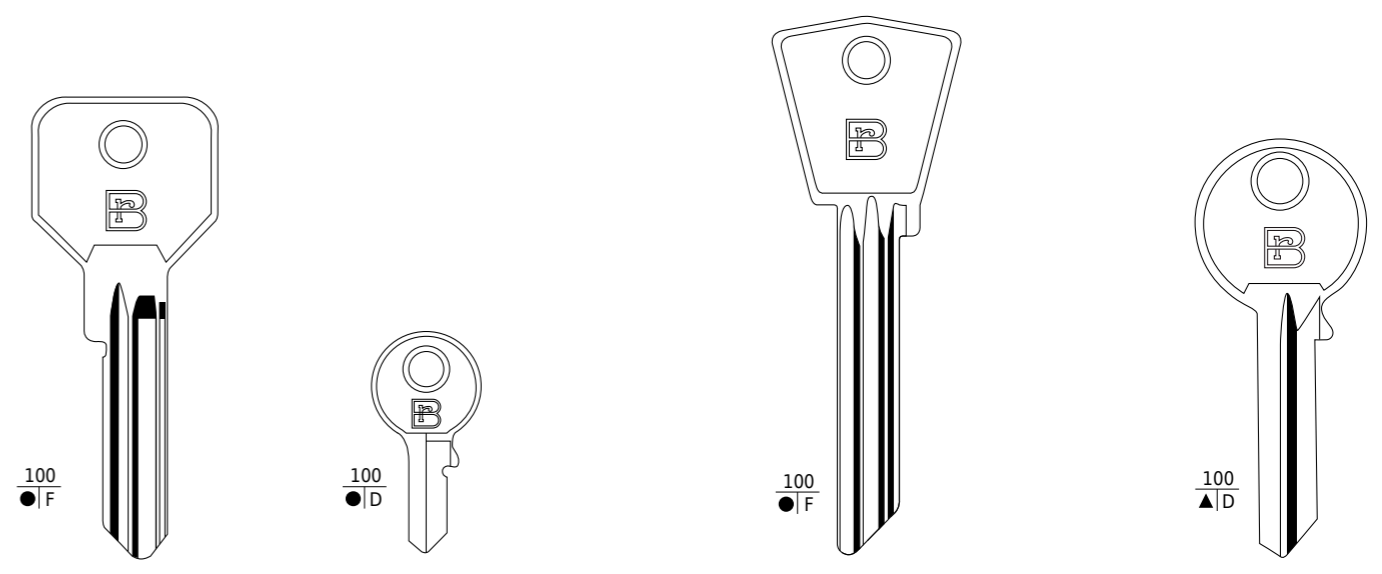

CI38
100
●/F
S. CS143
E. C38

CI23
100
●/D
S. CS23

CL6
100
●/F
S. CIL6
E. GN8D
K. CL4

CT1
100
▲/D
S. CA2
E. CT5S
K. CY2S



CORBIN

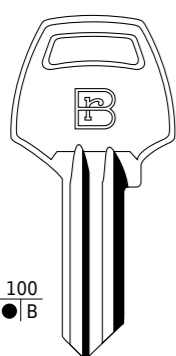

100
●|B

CO4DX



S. CB2
E. CO4D
F. COR40D

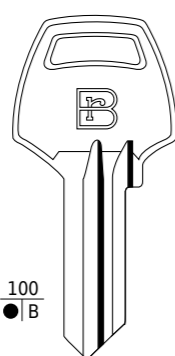

100
●|B

CO4SX



S. CB2R
E. CO4S

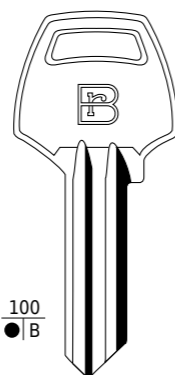

100
●|B

CO5DX



S. CB1
E. CO5D
F. COR50D

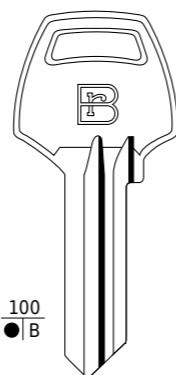

100
●|B

CO5SX



S. CB1R
E. CO5S
K. COR50S

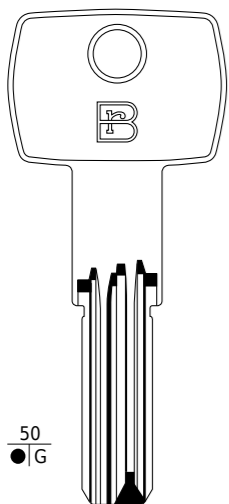

50
●|G

CO10



S. CB97
E. CO58
K. COR97

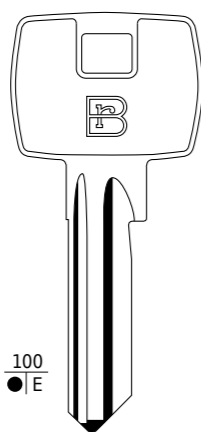

100
●|E

CO30



S. CB30
E. CO22
K. COR30

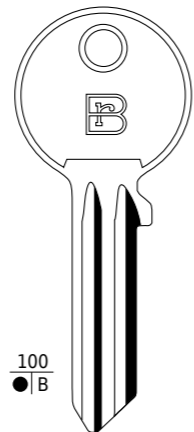

100
●|B

CO6DX



S. CB6
E. CO6T
K. COR6D

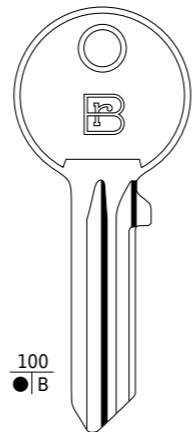

100
●|B

CO6SX



S. CB6R
E. CO6S
K. COR6S

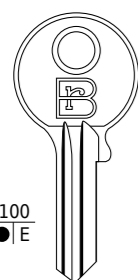

100
●|E

CO1



S. CB70
E. CO25

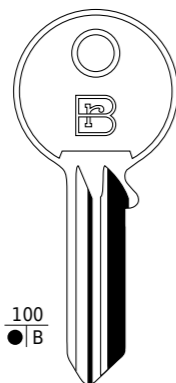

100
●|B

CO2



S. CB85
E. CO42
K. COR68

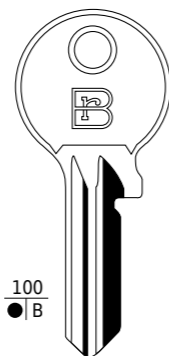

100
●|B

CO3



S. CB3/CB80
E. CO33
K. COR80

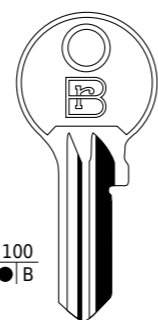

100
●|B

CO4



S. CB4/CB81
E. CO32
T. COR4PD

CORNI

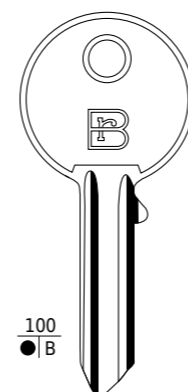

100
●|B

CC5DXR



S. CC1
T. CC5PD
K. CR5PD

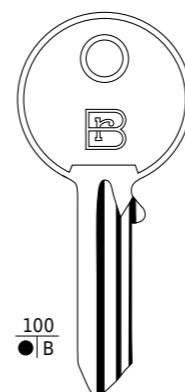

100
●|B

CC5SXR



S. CC1R
E. CC5PS
K. CR5PS

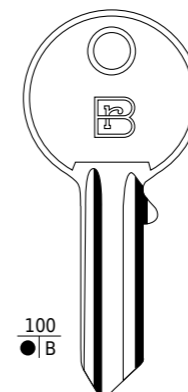

100
●|B

CC4DX



S. CC3
E. CC4D
K. CR4

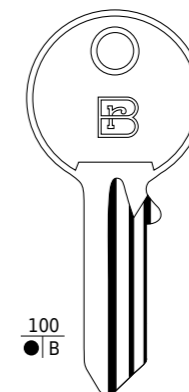

100
●|B

CC4SX



S. CC3R
E. CC4S
K. CR4S

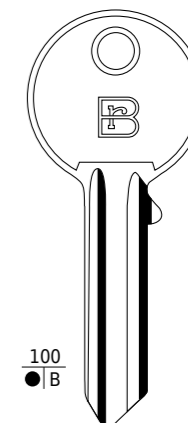

100
●|B

CC5DX



S. CC2
E. CC5D
K. CR5

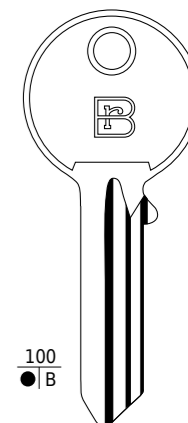

100
●|B

CC5SX



S. CC2R
E. CC5S
K. CR5S

DEXTER (MERONI)

DOM

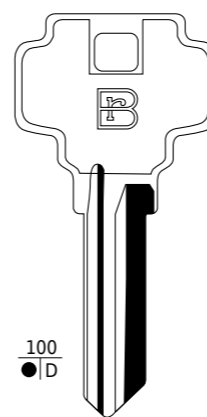

100
●|D

DE5DX



S. DX1/MER8
E. D5D/MR9
K. DE5D

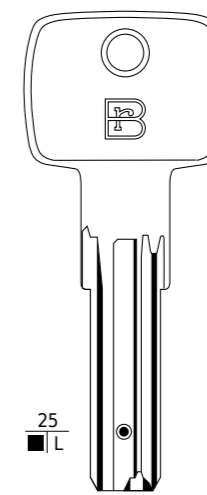

25
■|L

DM5



S. DM139
E. DM75LB
K. DO100X

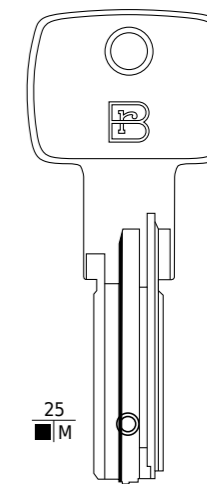

25
■|M

DM6



S. DM144
E. DM102



EURO LOCKS

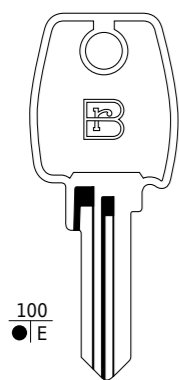

100
●|E

LF16



S. LF16
E. LF18R
K. LF25

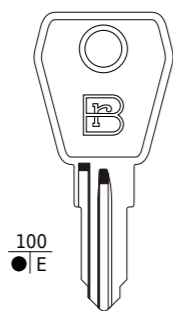

100
●|E

LF30



S. LF30R
E. LF28
K. LF26

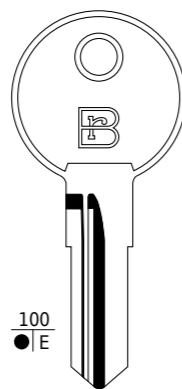

100
●|E

EU35



S. EU10R
E. EL5R
K. EU10S

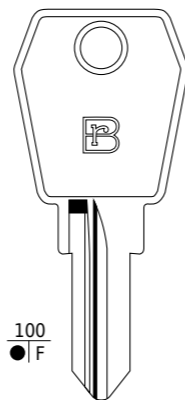

100
●|F

EU25



S. EU5R
E. EL3R
K. LF3S

FIAM

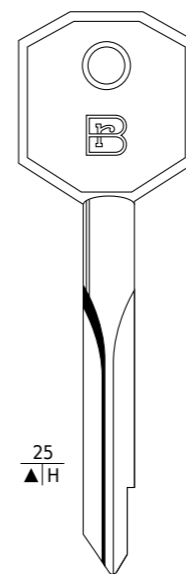

25
▲|H

FX1

1.0 $\frac{+}{-}$ $\frac{+}{-}$ 1.5

S. XF2
E. FMX70
K. XFIA2P

FIAM POTENT

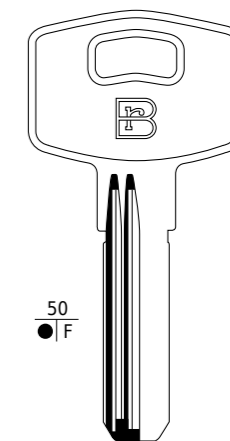

50
●|F

FI4R



S. FI4R/PT4R
E. FM4/PN1R
K. FIA7/POT4

FASEM

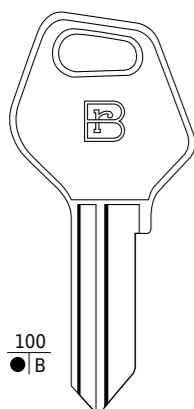

100
●|B

FA4SIM



S. FM1/FM2
E. FB5
T. FM4SM

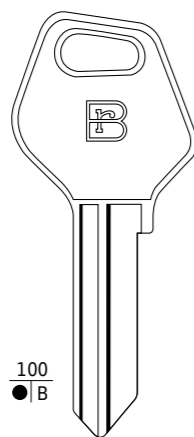

100
●|B

FA5SIM



S. FM6/FM090
E. FB1
T. FM50SM

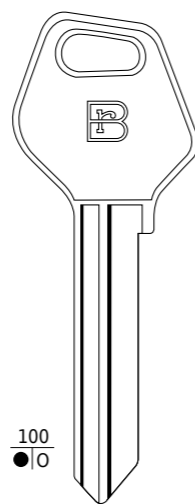

100
●|O

FA7SIM



S. FM7
E. FB4

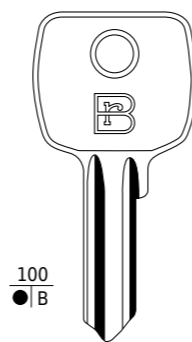

100
●|B

FA10



S. FM5
K. BET1

GIUSSANI

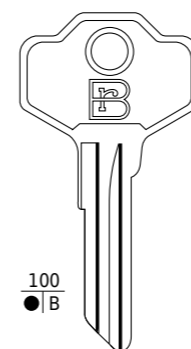

100
●|B

GI1

S. SM1
E. GU1
K. GIS5PS

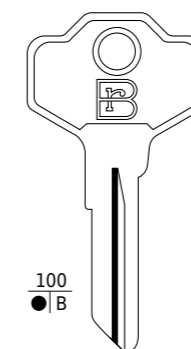

100
●|B

GI2

S. SM1R
E. GU1R
K. GIS5PD

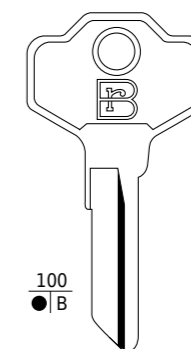

100
●|B

GI3

S. GS1R
E. GU3R

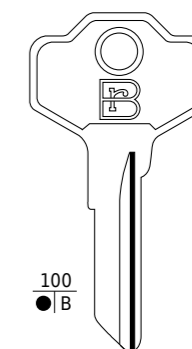

100
●|B

GI4

S. GS1
E. GU3
K. GIS1PD

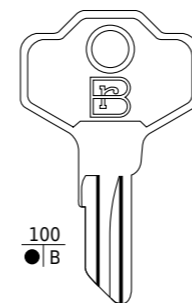

100
●|B

GI5

S. MER6
E. MRP4

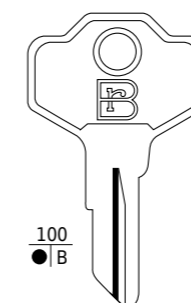

100
●|B

GI6

S. MER7R
E. MR8

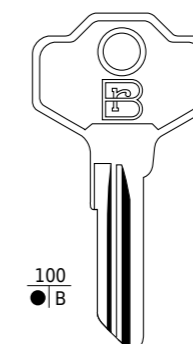

100
●|B

GI7

S. GS4R
E. GU4R
K. GIS4S

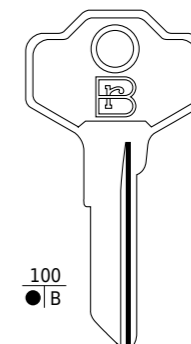

100
●|B

GI8

S. GS4
E. GU4
K. GIS4

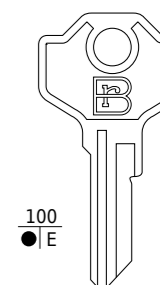

100
●|E

GI13

S. GS13
E. GU8
K. GIS2PD



ISEO

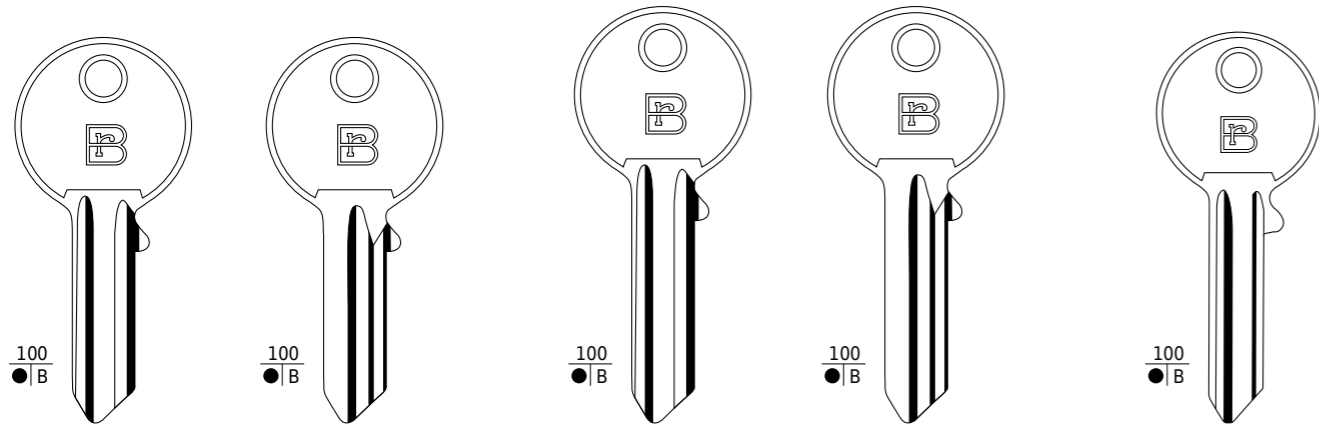

IS4DX

IS4SX

IS5DX

IS5SX

IS5DXR

S. IE7
E. I6
F. ISE4D



S. IE7R
E. I6R
K. ISE4S

S. IE6
E. I7
F. ISE5D

S. IE6R
E. I7R
K. ISE5S

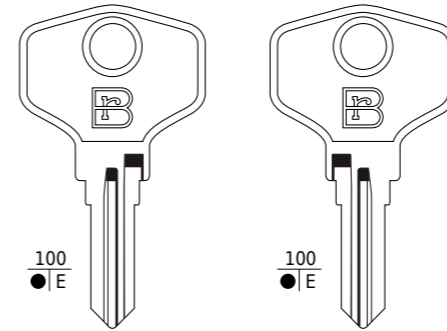

S. IE3
E. I5PD
K. ISE5PD

HOPPE



HP1

HP1S

S. HPP1
E. BG36
K. HOP1

S. HPP1R
E. BG36R
K. HOP1S

JPM

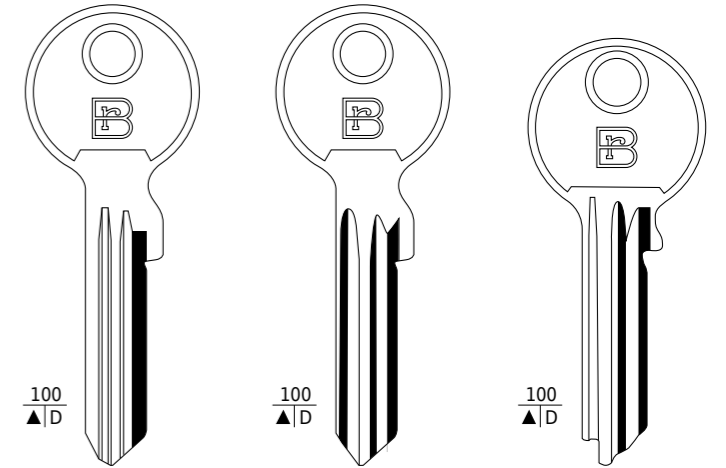



JP2

JP6

JP4

S. JM2R
E. AU42
K. JM2S

S. JM1
E. AU16
K. JM1

S. JM6
E. JPM4

KABA

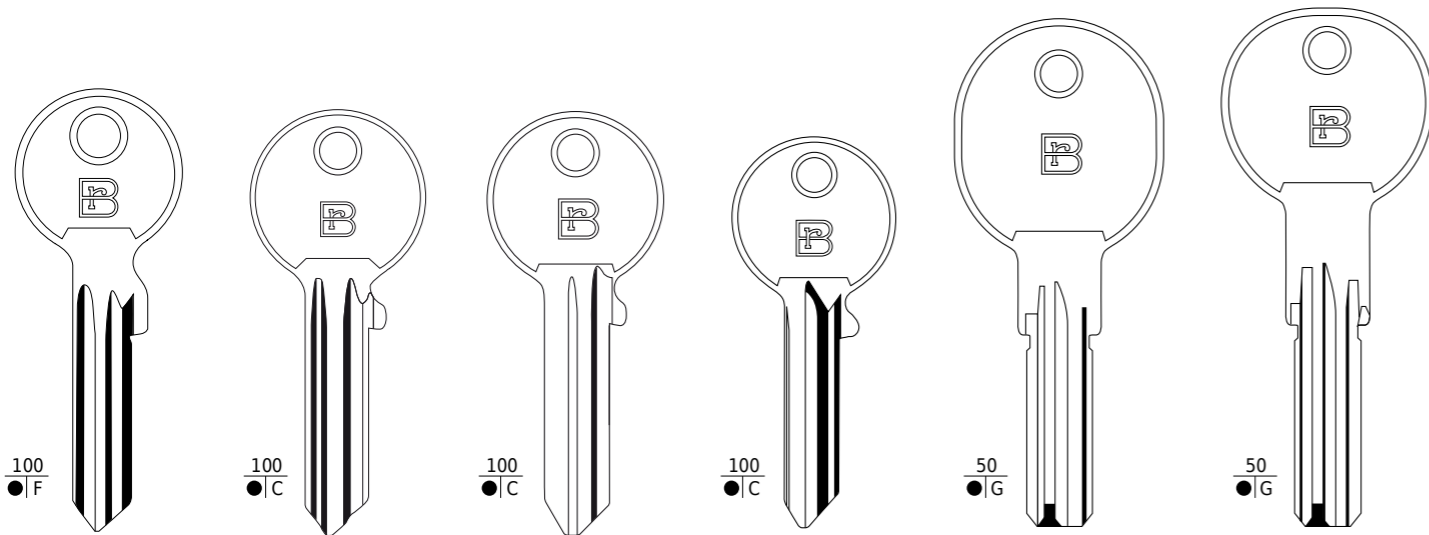

IS28

IS29

IS30

IS31

IS35

IS36



S. IE2 9
E. I19
K. ISE29

F3 - SILVER
S. IE31
E. I21
K. ISE31



S. IE27R
E. I17R
K. ISE27S

S. IE28R
E. I18R
K. ISE28

S. IE15
E. I15
K. ISE15

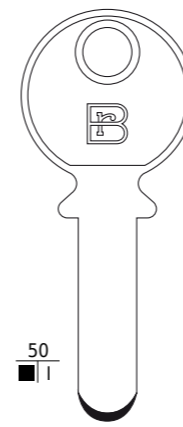

R6 PLUS
S. IE26
E. I16
K. ISE17

KYR



KA1

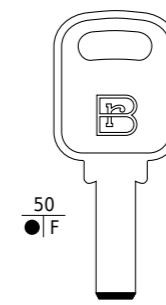

S. KA1
E. KB1
K. KA1



KY1

S. SCU1
E. SCU1
K. KYR1

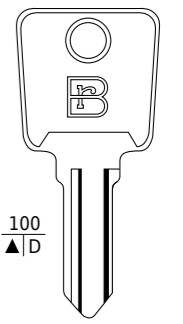
LAS



LA1



S. LS13
E. LAS9N
K. LAS9

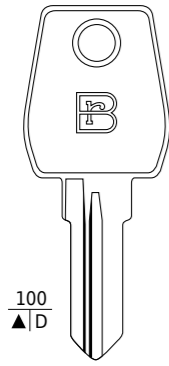

L & F

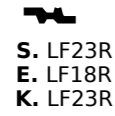

LF2



S. LF23R
E. LF18R
K. LF23R

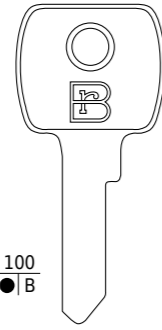

LF1



S. LF4
E. LF6
K. LF85

MASTER

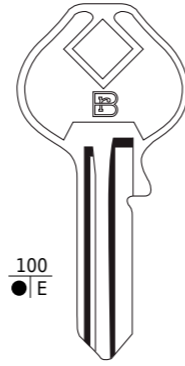

MS6



S. MS6
E. M12
K. CA18

MERONI

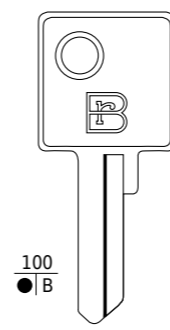

ME2



S. MER2
E. MR6
K. ME40PD

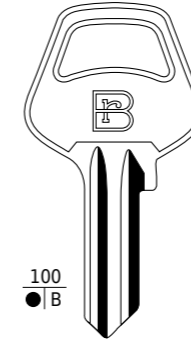

ME4DXR



S. MER1
E. MR4D
K. ME41PD

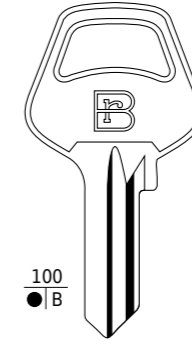

ME4SXR



S. MER1R
E. MR4S
K. ME41PS

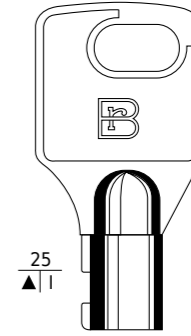

ME22T



S. MER22T
E. MR23T
K. ME17T

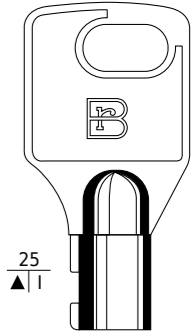

ME25T



S. MER25T
E. MR24T
K. ME18T

MERONI

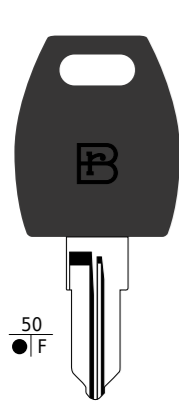

ME31
CG

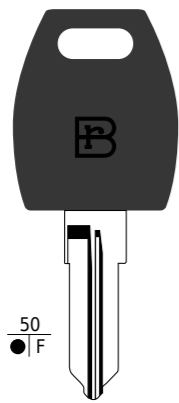

ME32
CI



S. MER42R

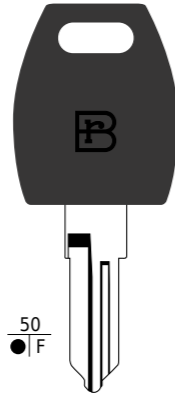

ME33
CB



S. MER33R
E. MR29R

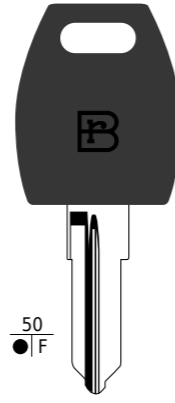

ME34
CC



S. MER34R
E. MR30R
K. ME34

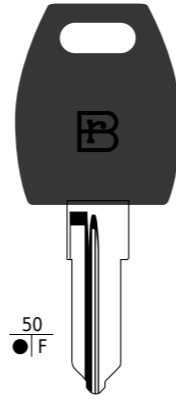

ME35
CD



S. MER35R
E. MR31R
K. ME35

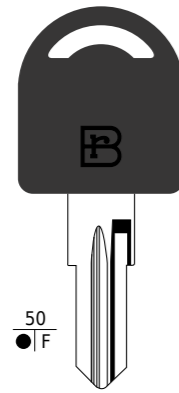

ME36



S. MER36/ED2
E. MR32
K. EVD4

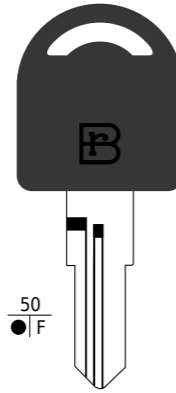

ME38
CO

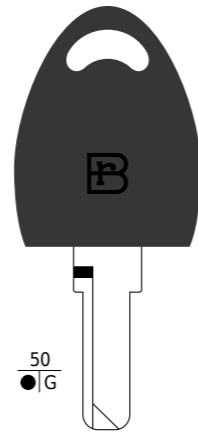

ME39



S. MER39
E. MR33
K. ME39

MG

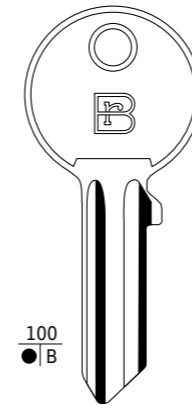

MG4DX



S. MN8
E. MG8
K. MN1

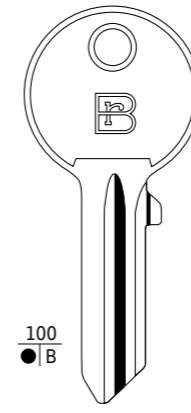

MG4SX



S. MN8R
E. MG8R
K. MN1S

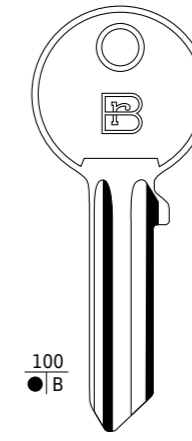

MG5DX



S. MN9
E. MG9
K. MN3

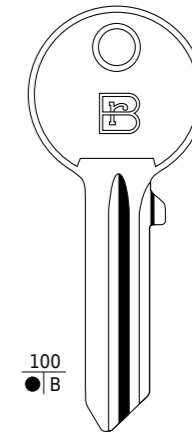

MG5SX



S. MN9R
E. MG9R
K. MN3S

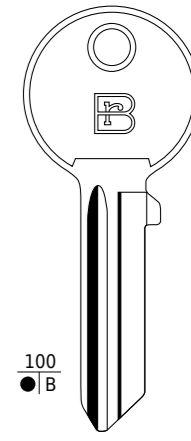

MG5SIM



S. MN1
E. GMSN

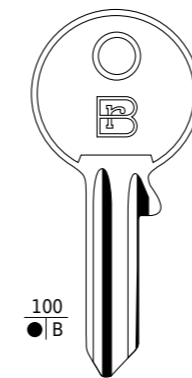

MG4DXR



S. MN6
T. MG4PD

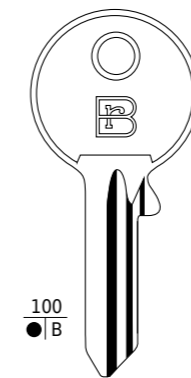

MG4SXR



S. MN6R
E. MG4PS

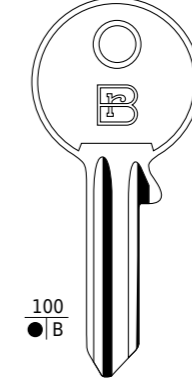

MG5DXR



S. MN5
T. MG5PD

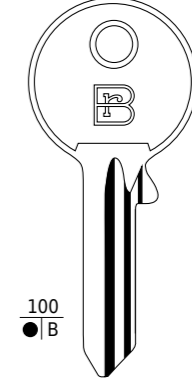

MG5SXR



S. MN5R
E. MG5PS



MG

MOTTURA

O.M.R.

P.C. CORTELLEZZI

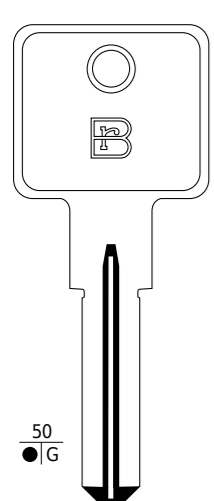

MG1

S. MG8
E. MG10
K. MN9

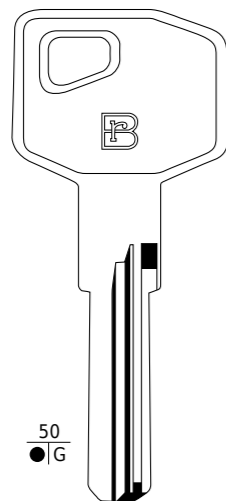

MG2

S. MG9
E. MG11
K. MN2S

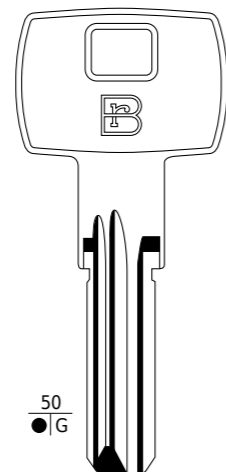

MT30

S. GYY1R
E. GEV1
K. MRI1

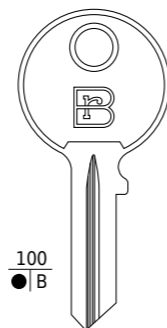

OMR1

S. OMR1R
E. SA1R
K. OMR1S

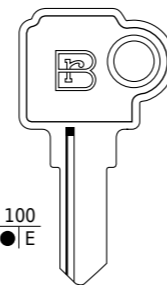

OMR2

S. SEAT
E. MIC9
K. SE1

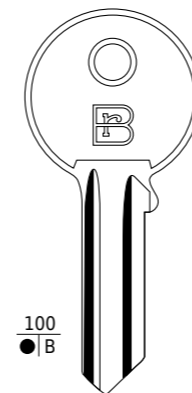

PC4DX

S. PC4
E. PA4D

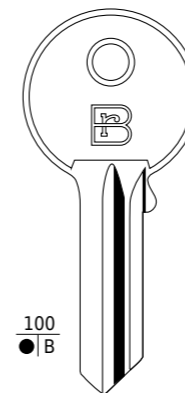

PC4SX

S. PC4R
E. PA4S

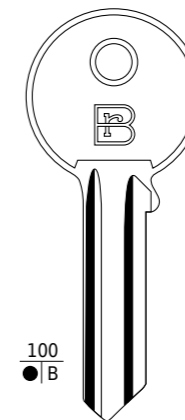

PC5DX

S. PC1
E. PA5D
K. PC1

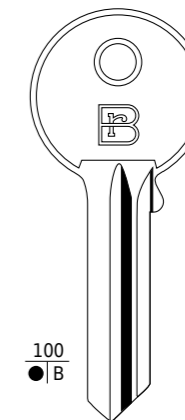

PC5SX

S. PC1R
E. PA5S

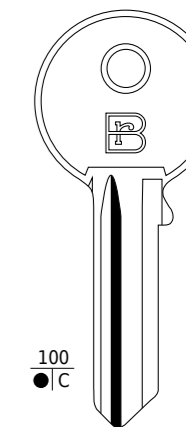

PCJL5

S. RM1A
E. PA9R
K. PC10S

OMEC

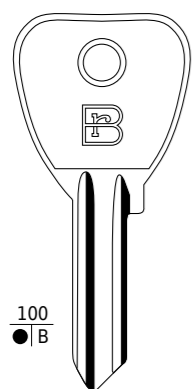

OM5DXR

S. OC074
E. O5PD
K. OMC5PD

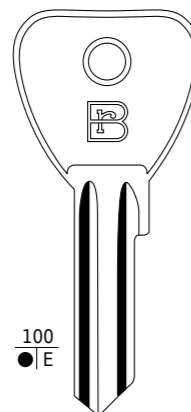

OM5DX

S. OC5
E. O9
F. OMC10

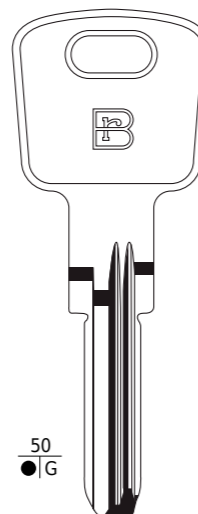

OM10

S. OC6
E. O8
F. OMC6

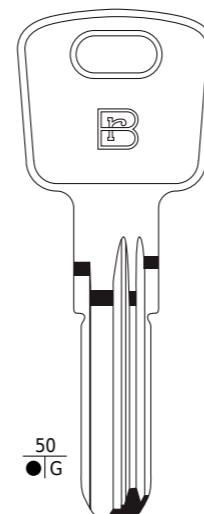

OM11

S. OC4
E. O7
K. OMC14

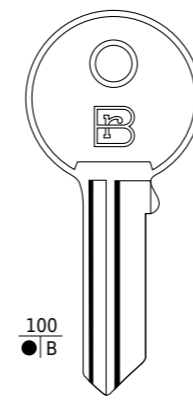

PC4SIM

S. PC20

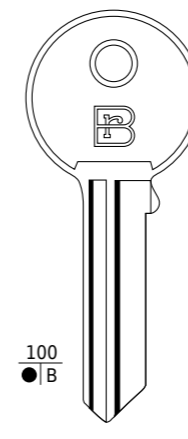

PC5SIM

S. PC14
E. FB3

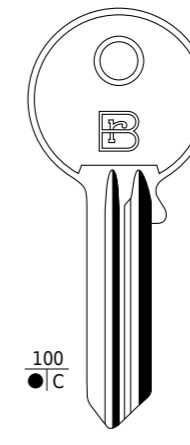

PC31S

S. PC31R
E. PA11R
K. PC12S

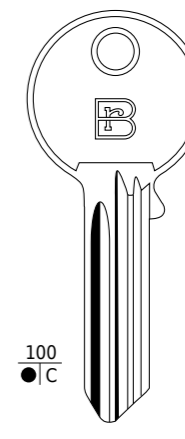

PC33S

S. PC33R
E. PA14R

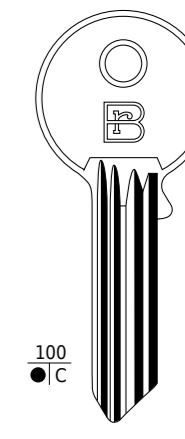

PC33

S. PC33

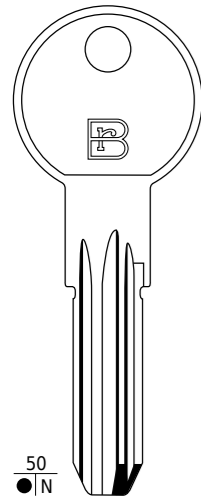
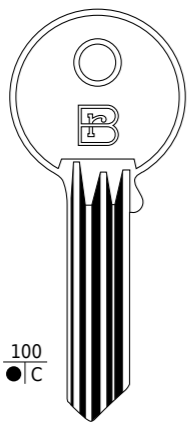
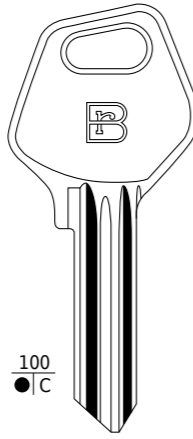
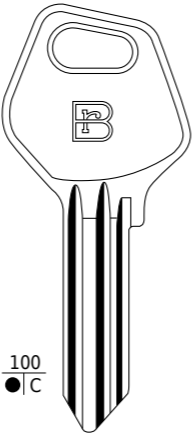
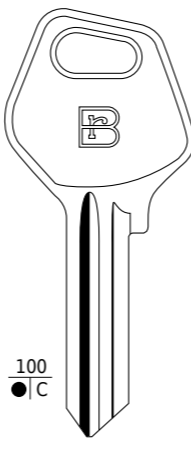

P.C. CORTELLEZZI

| | | | | |
|---|---|---|--|---|
|  50 ●/N |  100 ●/C |  100 ●/C |  100 ●/C |  100 ●/C |
| PC19 S. FF19 E. FF21 | PC26 S. PC26 E. PA10 | PC27 S. PA13R K. PC11S | PC24 S. VL5E E. JV2 | PCVL2S S. VL5RE E. JV2R |

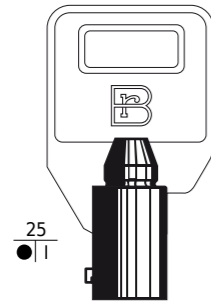
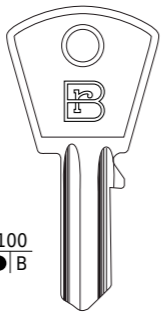
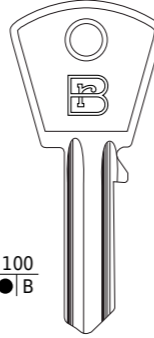
| | | |
|---|--|---|
|  25 ●/T |  100 ●/B |  100 ●/B |
| PC10T S. PC15T E. PA7T K. PC2T | PC3DXR S. PC3 E. PA3PD K. PC9 | PC4DXR S. PC2 E. PA4PD K. PC8 |

POTENT

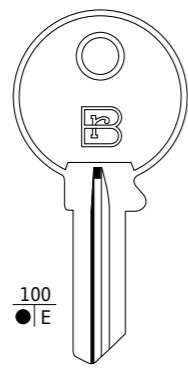
| |
|---|
|  100 ●/E |
| POT1 S. PT1 E. MIC4R K. POT1S |

PREFER

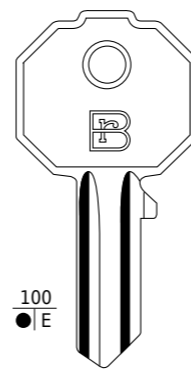
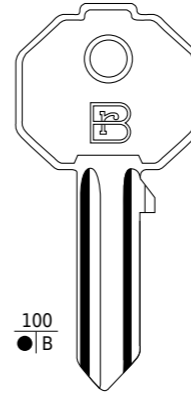
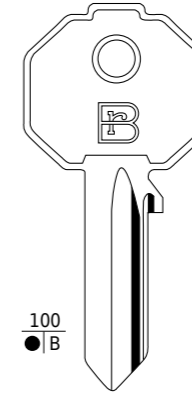
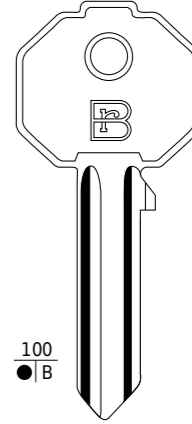
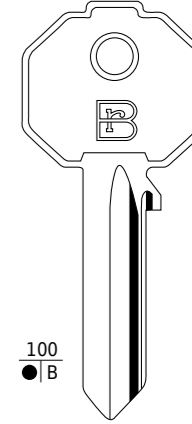
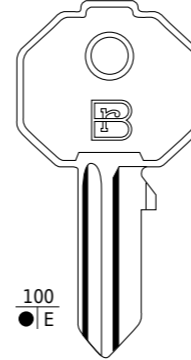
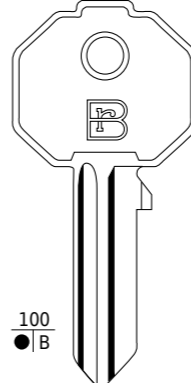
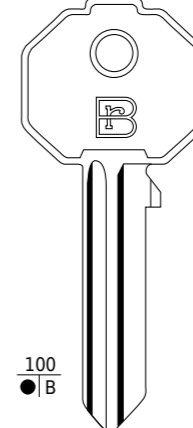
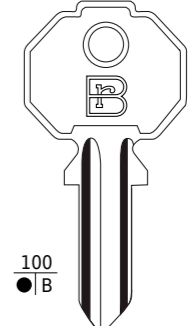
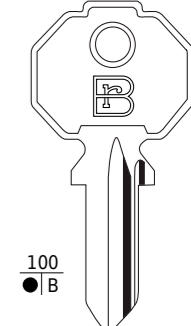
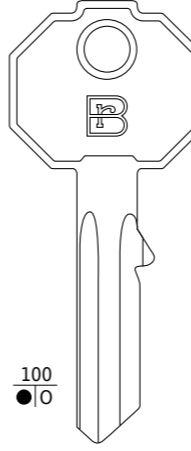
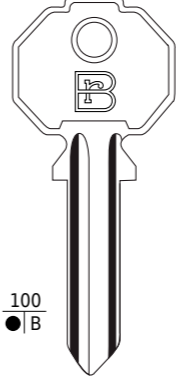
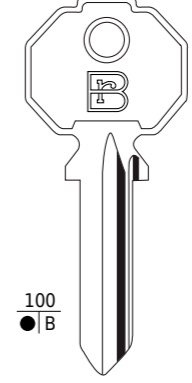
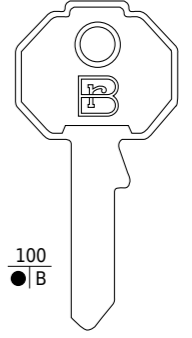
| | | | | |
|---|---|---|---|--|
|  100 ●/E |  100 ●/B |  100 ●/B |  100 ●/B |  100 ●/B |
| PR3DX S. PF208 E. P3D K. PR3D | PR4DX S. PF212 E. P4D K. PR4D | PR4SX S. PF213 E. P4S K. PR4S | PR5DX S. PF210 E. P5D K. PR5D | PR5SX S. PF211 E. P5S K. PR5S |
|  100 ●/E |  100 ●/B |  100 ●/B |  100 ●/B |  100 ●/B |
| PR3SIM S. PF5S E. PS3M K. PR3SS | PR4SIM S. PF2S E. PS4M K. PR4SS | PR5SIM S. PF092S E. PS5M K. PR5SS | PR4DXR S. PF070 E. P4PD K. PR4PD | PR4SXR S. PF071 E. P4PS K. PR4PS |
|  100 ●/O |  100 ●/B |  100 ●/B |  100 ●/B | |
| PRL4DX | PR5DXR S. PF072 E. P5PD K. PR5PD | PR5SXR S. PF073 E. P5PS K. PR5PS | PR1 S. PF1 E. P7R K. PR1D | |



PREFER

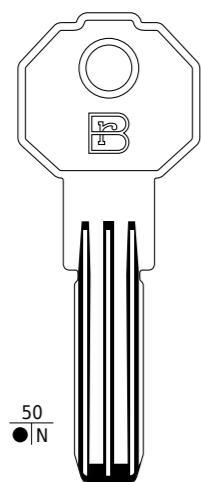

PR20



S. PF20
E. P15
K. PR16

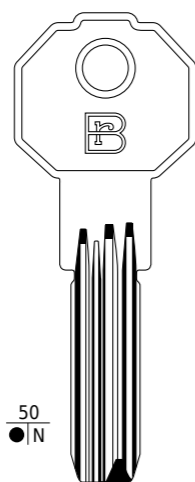

PR21



S. PF21
E. P16
K. PR17

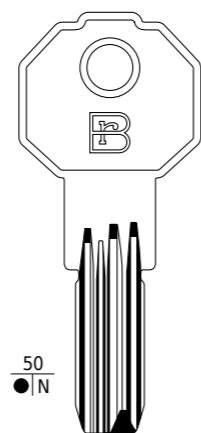

PR22



S. PF22
E. P17
K. PR18

SECUREMME

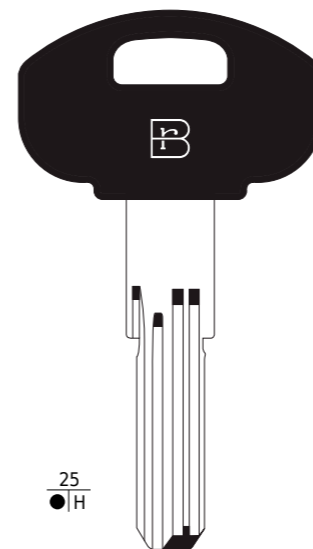

SCM1



S. SCM2
E. SEM7
K. SEC9

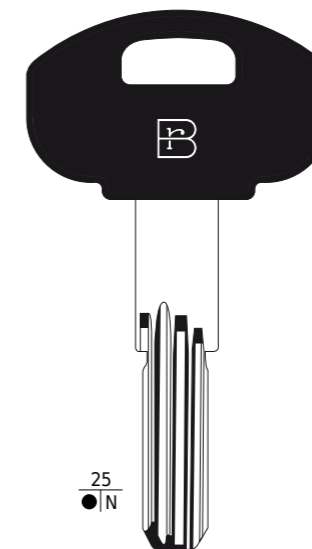

SCM2



S. SCM1R
E. SEM8
K. SEC11P

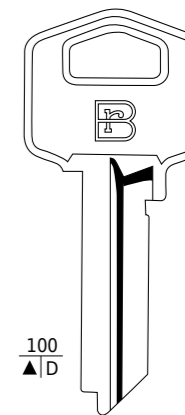

TS9



S. TE2
E. TS7R
K. TES5

RONIS

STUBLINA

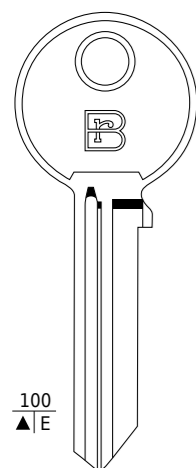

NE3



S. RO41
E. NE51
K. RI18

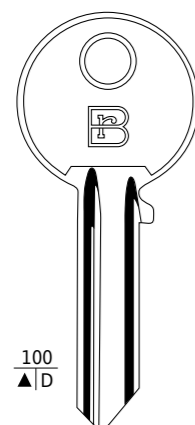

RO5DX



S. RO8
E. R5D
K. RI3

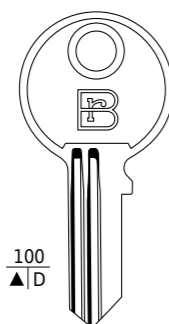

RO23



S. RO4
E. R23R
K. RI10

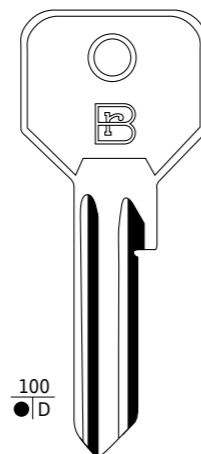

ST5DX



S. STN1

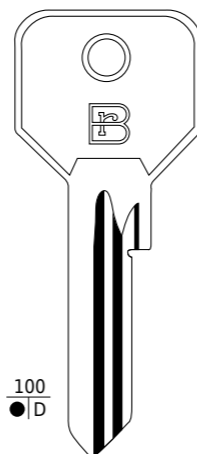

ST5SX



S. STN1R

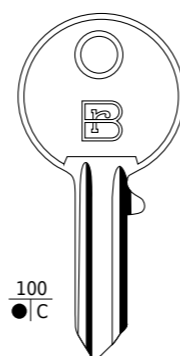

ST2



TIFON

TITAN

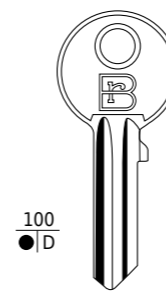

TFN2



S. TFN2
E. TFN1

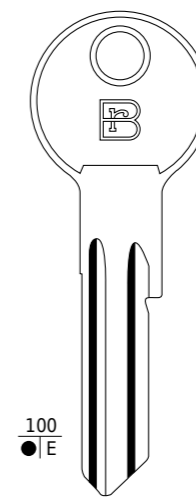

TT1A



S. TN16XA
E. TT5D
K. TIN6-B

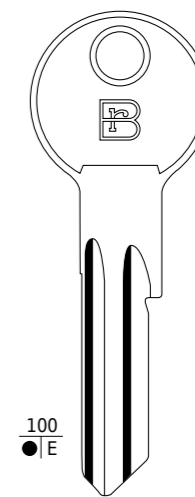

TT1Z



S. TN39

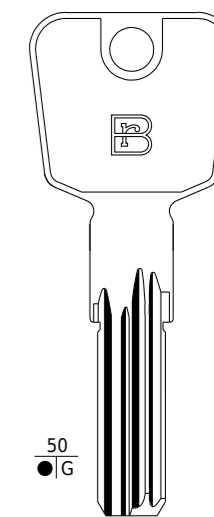

TT5



S. TN32
E. TT13
K. TIN7

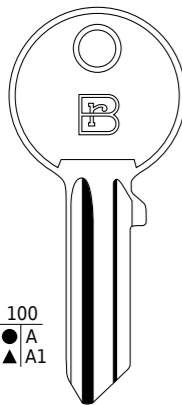
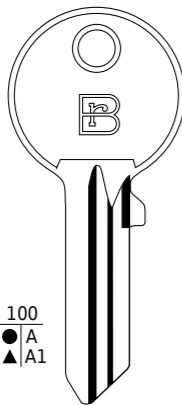
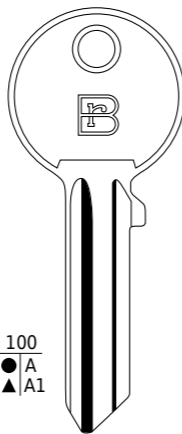
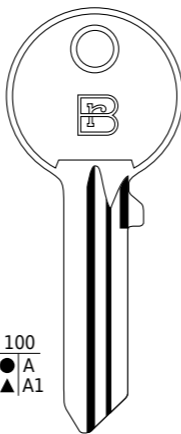
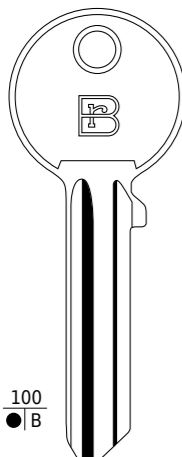
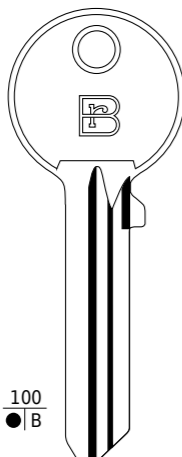
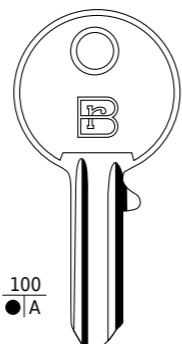
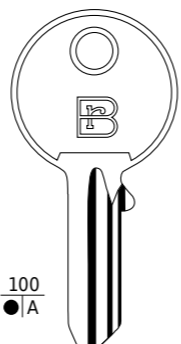
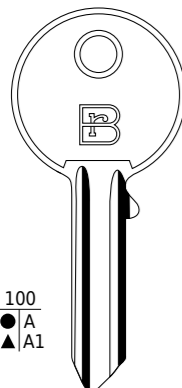
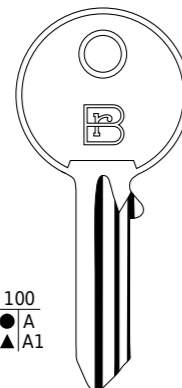
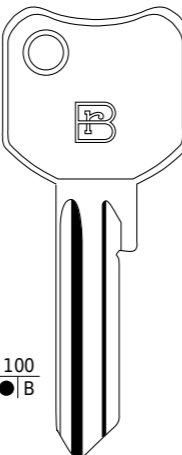
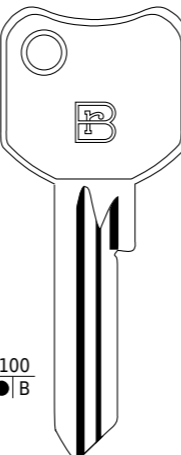

UNIVERSAL

| | | | |
|--|--|--|---|
|  <p>100 ● A ▲ A1</p> <p>UN4DX S. UL052 E. U4D K. UN4D</p> |  <p>100 ● A ▲ A1</p> <p>UN4SX S. UL053 E. U4S K. UN4S</p> |  <p>100 ● A ▲ A1</p> <p>UN5DX S. UL050 E. U5D K. UN5D</p> |  <p>100 ● A ▲ A1</p> <p>UN5SX S. UL051 E. U5S K. UN5S</p> |
|  <p>100 ● B</p> <p>UN6DX S. UL054 E. U6D K. UN6D</p> |  <p>100 ● B</p> <p>UN6SX S. UL055 E. U6S K. UN6S</p> |  <p>100 ● A</p> <p>UN4DXR S. UL060 E. U4PD K. UN4PD</p> |  <p>100 ● A</p> <p>UN4SXR S. UL061 E. U4PS K. UN4PS</p> |
|  <p>100 ● A ▲ A1</p> <p>UN5DXR S. UL058 E. U5PD K. UN5PD</p> |  <p>100 ● A ▲ A1</p> <p>UN5SXR S. UL059 E. U5PS K. UN5PS</p> |  <p>100 ● B</p> <p>UNQ5DX S. UL050 E. U5D K. UN5D</p> |  <p>100 ● B</p> <p>UNQ5SX S. UL051 E. U5S K. UN5S</p> |

VACHETTE

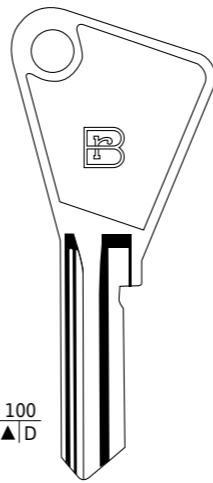
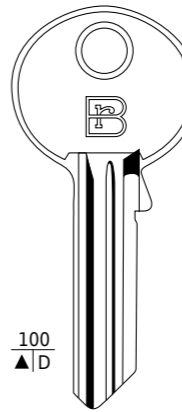
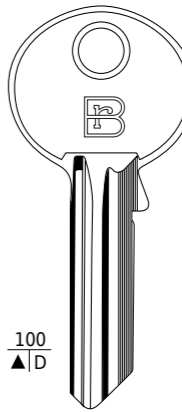
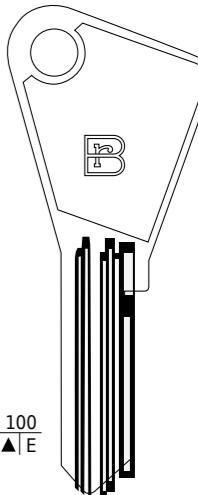
| | | | |
|---|---|--|---|
|  <p>100 ▲ D</p> <p>VC5DX S. VAC2 E. VC5D K. VC2</p> |  <p>100 ▲ D</p> <p>VC6 S. LH42 E. LA3 K. LR10</p> |  <p>100 ▲ D</p> <p>VC8 S. VAC151 E. VC88 K. VC26</p> |  <p>100 ▲ E</p> <p>VCPP S. VAC48 E. VCPP K. VC8</p> |
|---|---|--|---|

VIRO

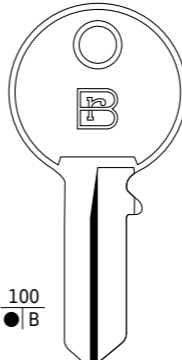
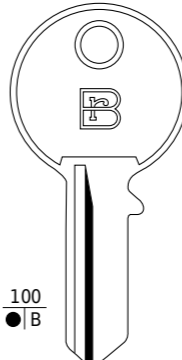
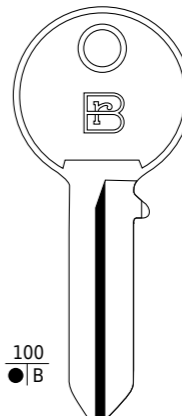
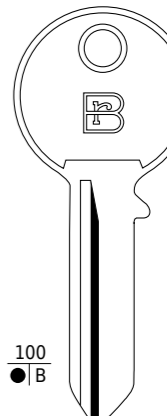
| | | | |
|--|--|--|--|
|  <p>100 ● B</p> <p>VI4DX S. VI082 E. V4D K. VR4D</p> |  <p>100 ● B</p> <p>VI4SX S. VI083 E. V4S K. VR4S</p> |  <p>100 ● B</p> <p>VI5DX S. VI080 E. V5D K. VR5D</p> |  <p>100 ● B</p> <p>VI5SX S. VI081 E. V5S K. VR5S</p> |
|--|--|--|--|



VIRO

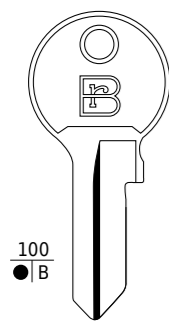

100
●|B

VI4DXR



S. VI084
E. V4PD
K. VR4PD

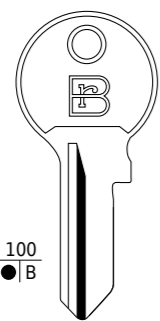

100
●|B

VI4SXR



S. VI085
E. V4PS
K. VR4PS

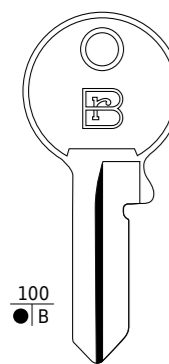

100
●|B

VI5DXR

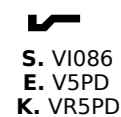

S. VI086
E. V5PD
K. VR5PD

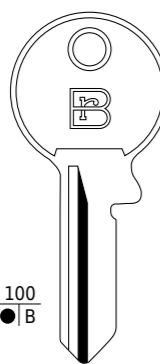

100
●|B

VI5SXR



S. VI087
E. V5PS
K. VR5PS

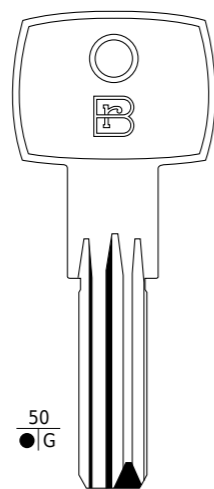

50
●|G

V18

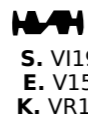

S. VI19
E. V15
K. VR19

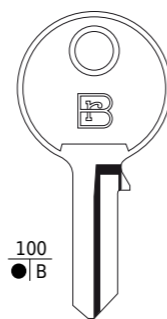

100
●|B

VI2

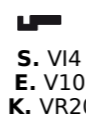

S. VI4
E. V10
K. VR20

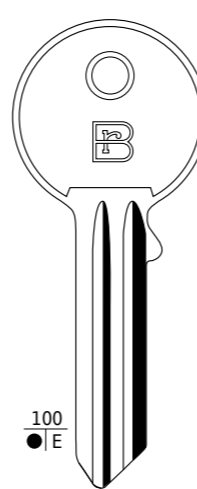

100
●|E

VI15
TS



S. VI5R
E. V7R
K. VR51S

WALLY

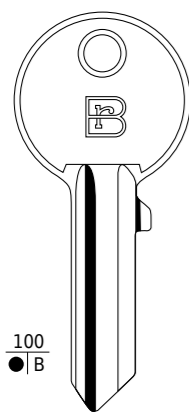

100
●|B

WA4DX



S. WA2
E. W4D
K. WY4D

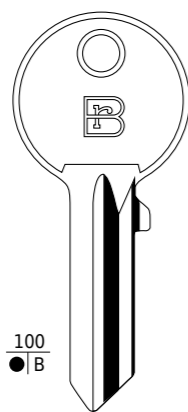

100
●|B

WA4SX

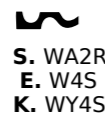

S. WA2R
E. W4S
K. WY4S

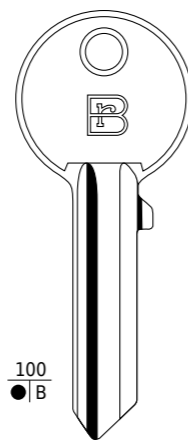

100
●|B

WA5DX



S. WA1
E. W5D
K. WY5D

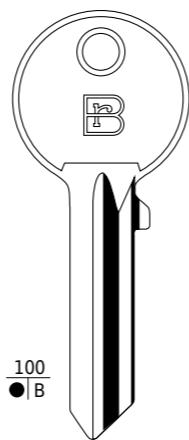

100
●|B

WA5SX

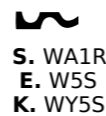

S. WA1R
E. W5S
K. WY5S

WELKA

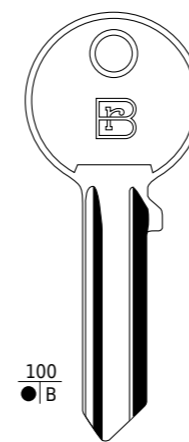

100
●|B

WK5DX



S. WE1
E. WK5D
K. WK5D

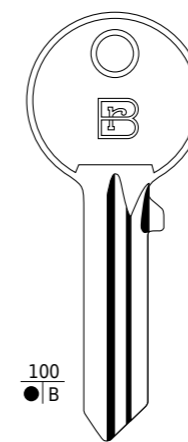

100
●|B

WK5SX



S. WE1R
E. WK5S
K. WK5S

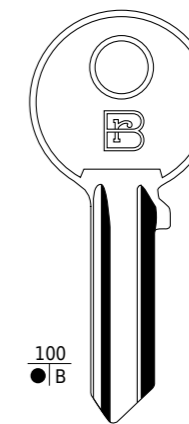

100
●|B

WKC5DX



S. WE7
T. WK5DN

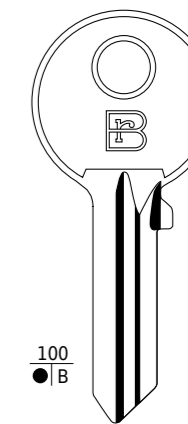

100
●|B

WKC5SX

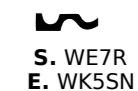

S. WE7R
E. WK5SN

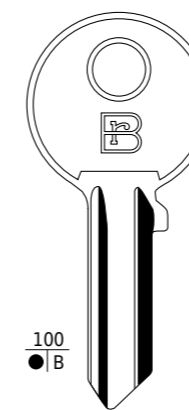

100
●|B

WK4DX

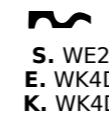

S. WE2
E. WK4D
K. WK4D

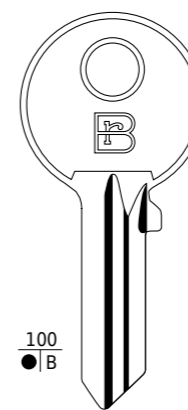

100
●|B

WK4SX

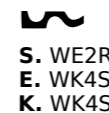

S. WE2R
E. WK4S
K. WK4S

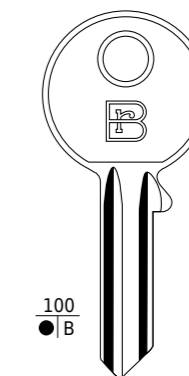

100
●|B

WK4DXR

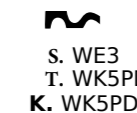

S. WE3
T. WK5PD
K. WK5PD

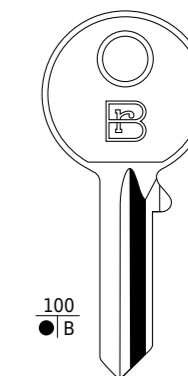

100
●|B

WK4SXR

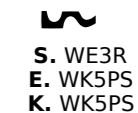

S. WE3R
E. WK5PS
K. WK5PS



YALE

| | | | | | |
|------------------------------|-------------------------------|--------------------------------|--------------------------------|-------------------------------|--------------------------------|
| | | | | | |
| $\frac{100}{\bullet B}$ | $\frac{100}{\bullet B}$ | $\frac{100}{\bullet B}$ | $\frac{100}{\bullet B}$ | $\frac{100}{\bullet C}$ | $\frac{100}{\bullet C}$ |
| YA4DX | YA4SX | YA5DX | YA5SX | YA6DX | YA6SX |
| | | | | | |
| S. YA6 E. YI4D K. YE4D | S. YA6R E. YI4S K. YE4S | S. YA226 E. YI5D K. YE5D | S. YA227 E. YI5S K. YE5S | S. YA31 E. YI6D K. YE6D | S. YA31R E. YI6S K. YE6S |

YETI

| |
|------------------------------|
| |
| $\frac{100}{\bullet E}$ |
| YE1 |
| |
| S. YT1 E. YE8 K. YET1S |

ZADI

| |
|--------------------------|
| |
| $\frac{100}{\bullet E}$ |
| ZD9 |
| |
| S. ZD7 ZD9 E. ZA5 ZA6 |

ZANI

| |
|-------------------------|
| |
| $\frac{100}{\bullet C}$ |
| ZA5DX |
| |
| S. ZI5 |

ZENITH

| | | | | |
|---------------------------------|----------------------------------|--------------------------------|---------------------------------|--------------------------------|
| | | | | |
| $\frac{100}{\bullet B}$ | $\frac{100}{\bullet B}$ | $\frac{100}{\bullet B}$ | $\frac{100}{\bullet B}$ | $\frac{100}{\bullet C}$ |
| YA4DXR | YA4SXR | YA5DXR | YA5SXR | YA91 |
| | | | | |
| S. YA13 E. YI4PD K. YE4PD | S. YA13R E. YI4PS K. YE4PS | S. YA7 E. YI5PD K. YE5PD | S. YA7R E. YI5PS K. YE5PS | S. YA91 E. YI6DM K. YE91 |

POSTALI

| | | | | |
|--------------------------------|--------------------------------|--------------------------------|------------------------|------------------------|
| | | | | |
| $\frac{100}{\blacktriangle E}$ | $\frac{100}{\blacktriangle E}$ | $\frac{100}{\blacktriangle B}$ | $\frac{50}{\bullet F}$ | $\frac{50}{\bullet F}$ |
| CZ2 | CZ3 | PP | PPA | PPB |
| | | | | |
| S. CA11 E. ZN6 K. ZN3 | S. CA8 E. ZN5D K. ZN4 | S. 1003P1 E. CPPS K. CP1 | | S. RC6 E. CN11 |

CHIAVI DOPPIA MAPPA



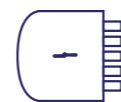

AUNO

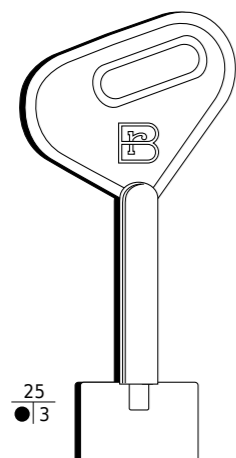

A1P1

S. 5AU3
E. 1AN9
K. 2AN

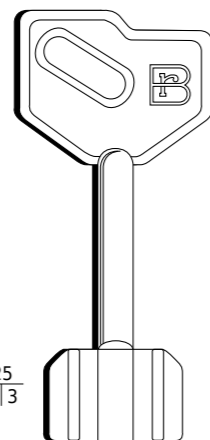

A1P2

S. 5AU13
E. 1AN13
K. 2AU13

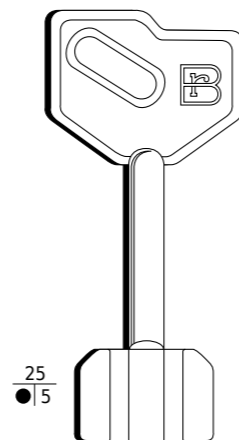

A1P7

S. 5AU7
E. 1AN11
K. 1AN2

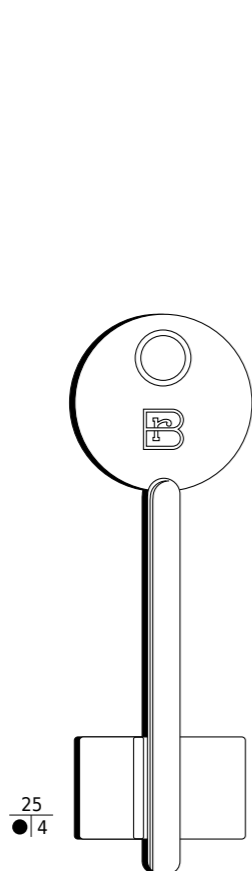

1A5

S. 5AU5
E. 1AN15

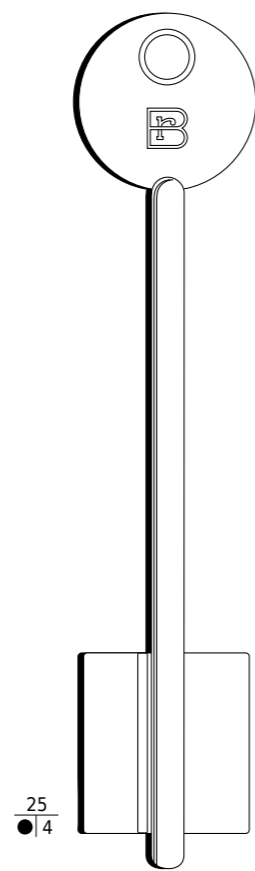

1A10

S. 5AU9
E. 2AN14
K. 2AU9

ANTONIOLI

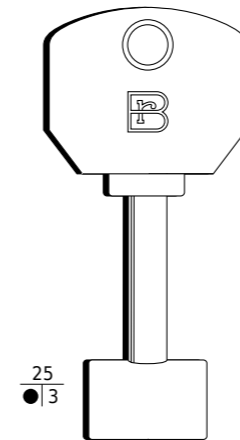

ANP6

S. 5A7
E. 1AN1N
K. 1AN

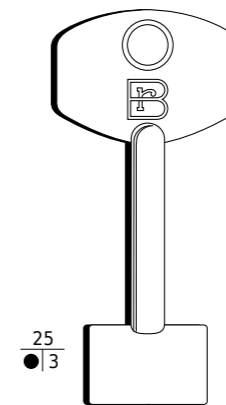

ANP3

S. APN
E. 1AN1L
K. 1AN3

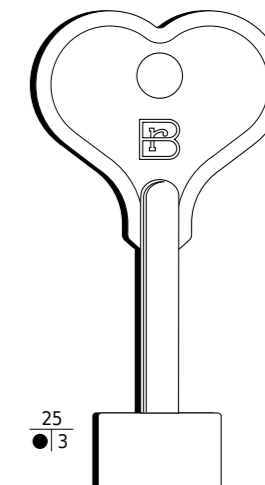

ANP8

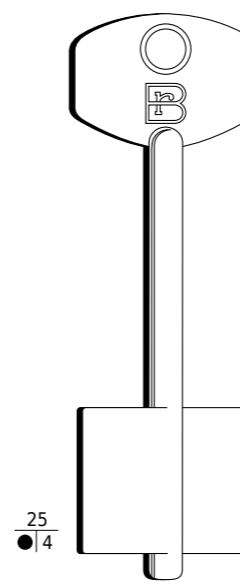

AN4

S. AML
E. 2AN5

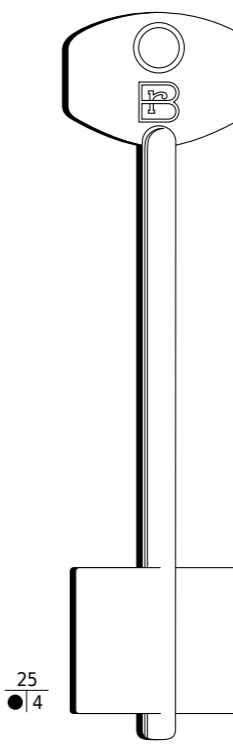

AN2

S. AL
E. 2AN3

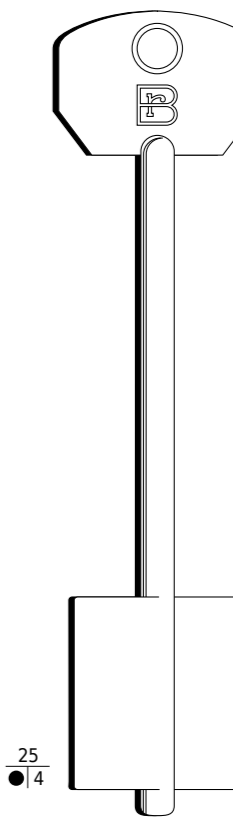

AN10

S. 5A6
E. 2AN4N

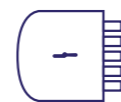

ANTONIOLI

ATRA

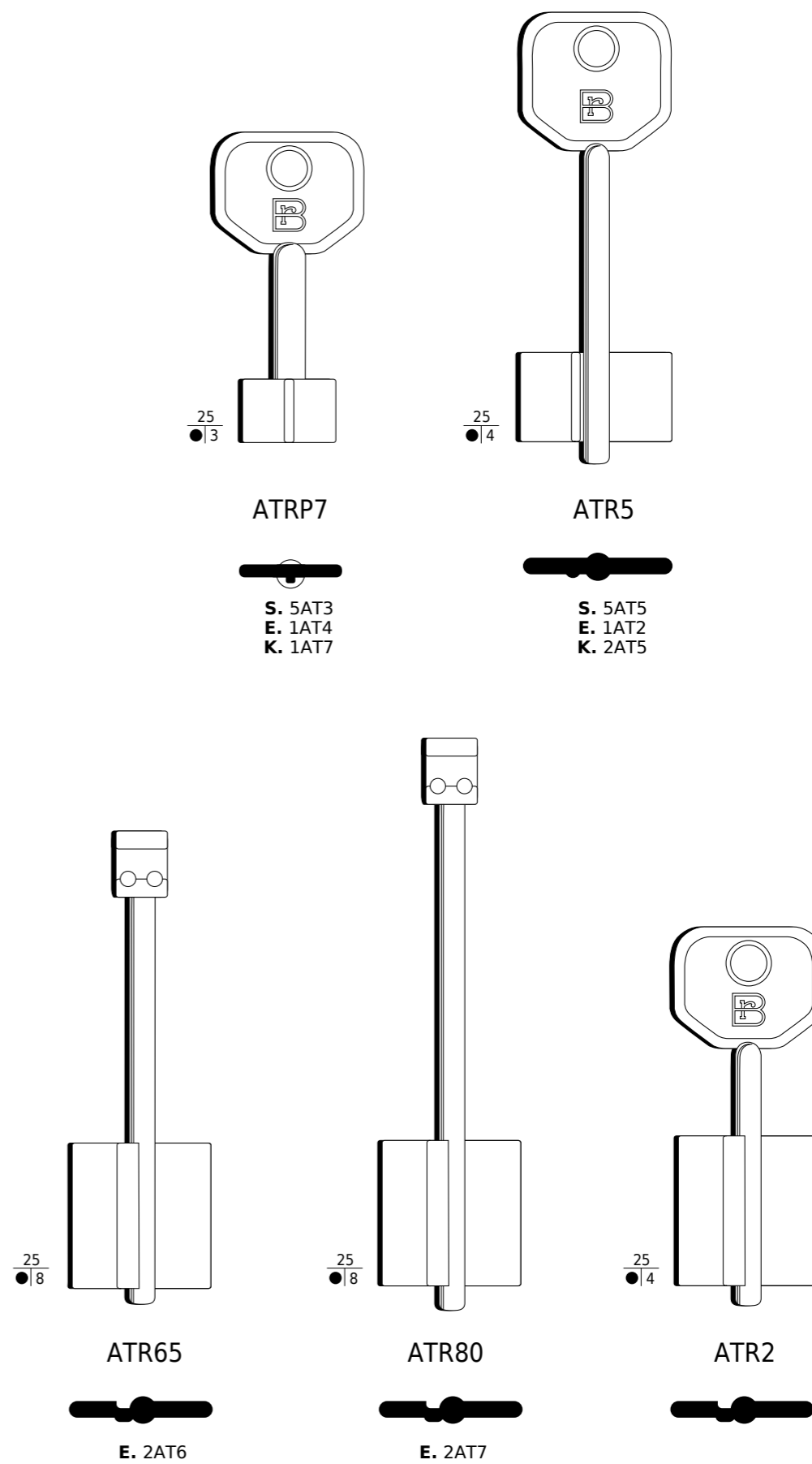
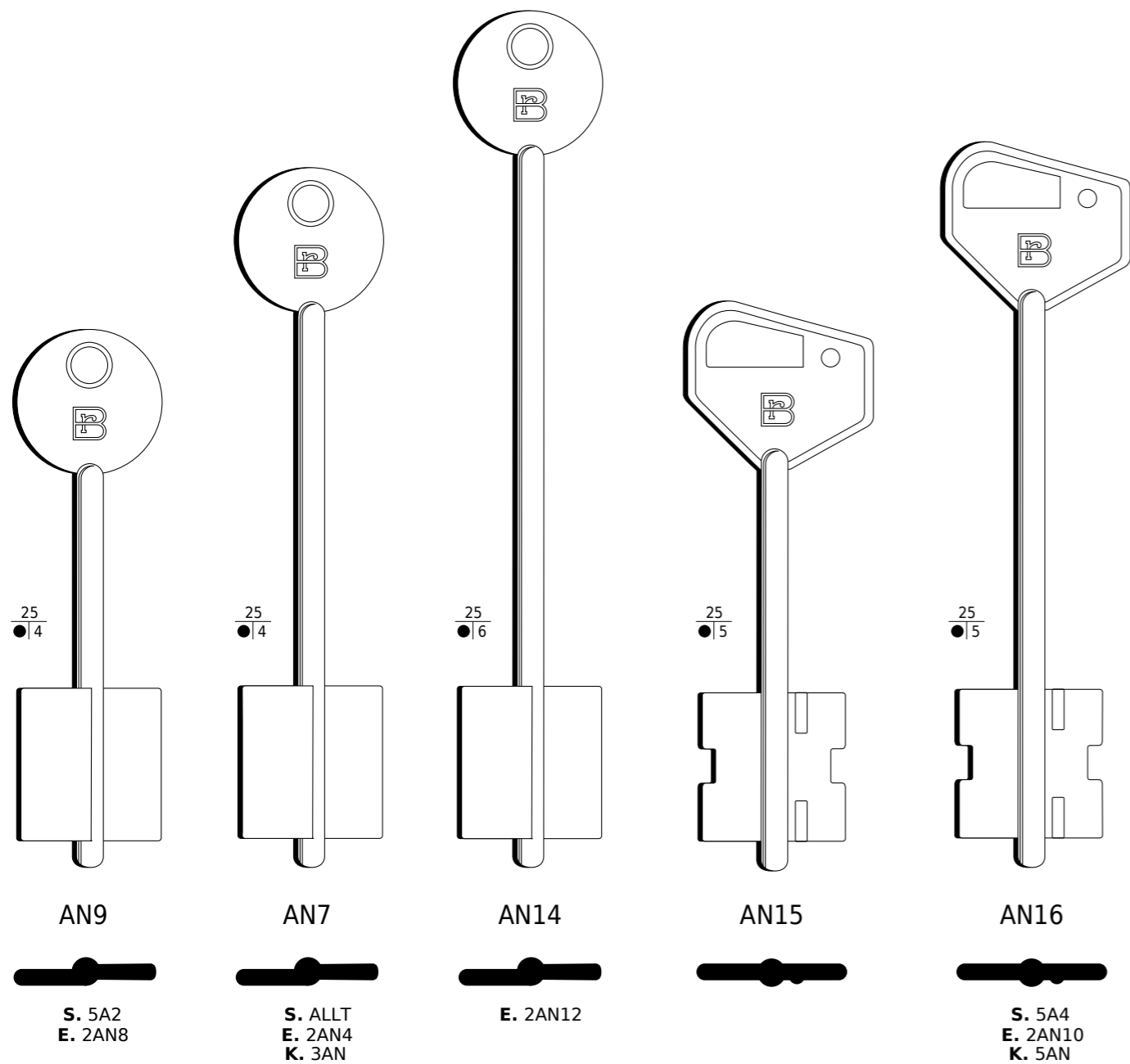

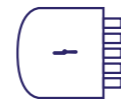

ATRA

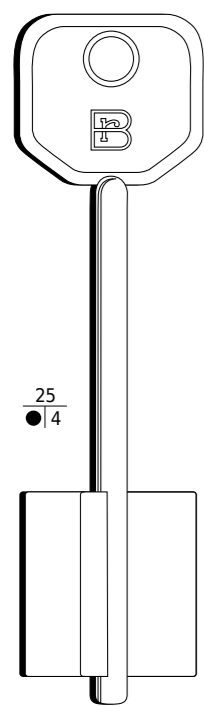

ATR1

S. 5AT1
E. 2AT1
K. 1AT

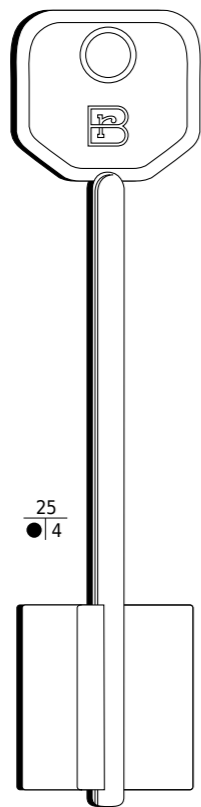

ATR9

S. 5AT7
K. 9AT

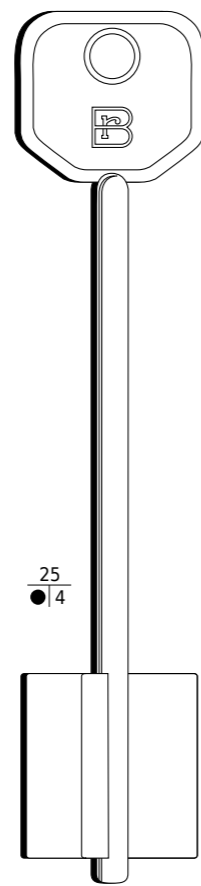

ATR3

S. 5AT9
E. 2AT3
K. 5AT

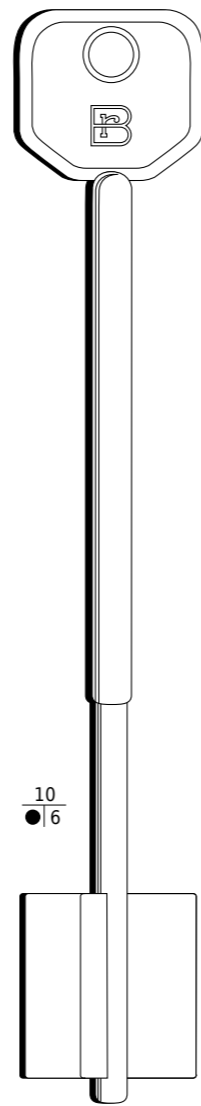

ATR10



BETA

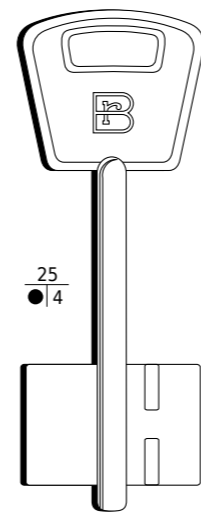

BE9

S. BES
E. 1BT4

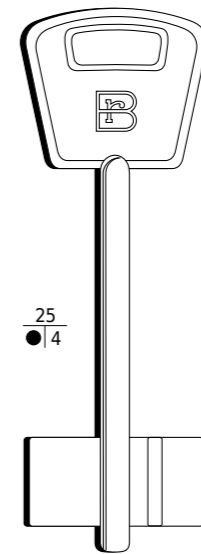

BE11

S. BE
E. 1BT1

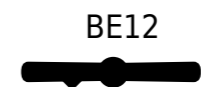

BE12

S. BEC
E. 1BT8

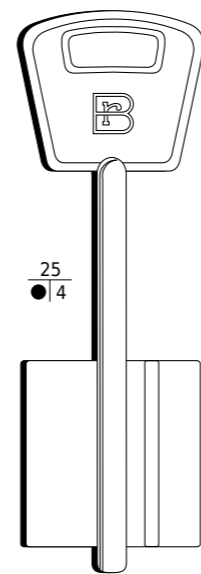

BE3

S. BEA
E. 1BT5
K. 2BE3

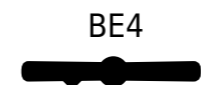

BE4

S. BEAC
E. 1BT5R
K. 2BE4

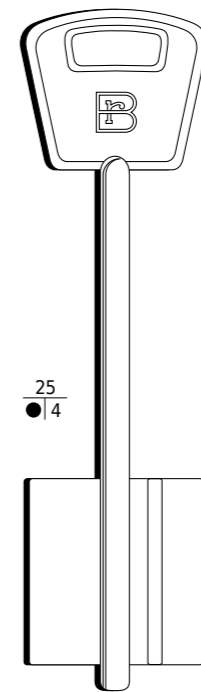

BE13

S. 5BE2
E. 2BT6

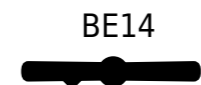

BE14

S. 5BE1
E. 2BT6R

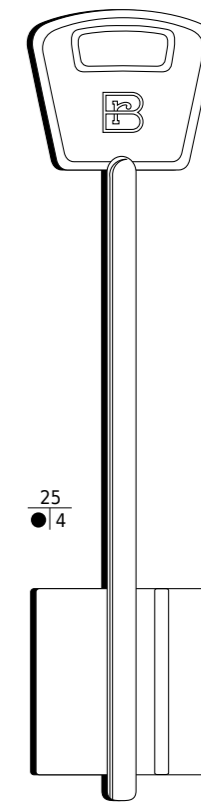

BE6

S. BEL
E. 2BT2
K. 2BE1

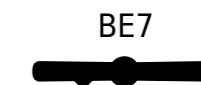

BE7

S. BELC
E. 2BT2R
K. 2BE2

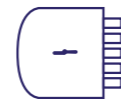

BMC

CAF

CERUTTI

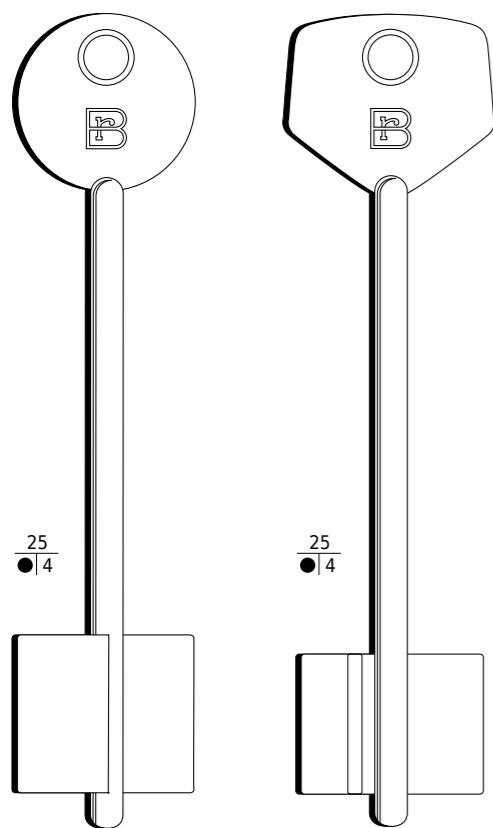

25
●/4

25
●/4

BM1

BM3



S. BL
E. 2BMC1



S. 5BL1
E. 2BMC2

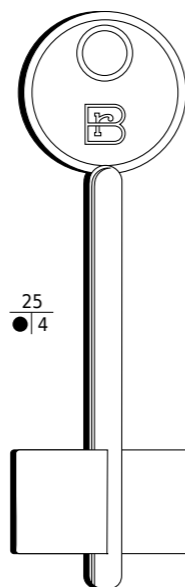

25
●/4

CA1



S. CF
T. 1CA1

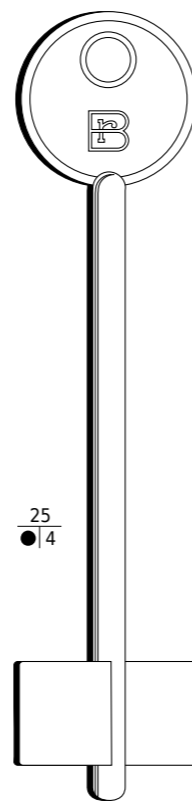

25
●/4

CA3



S. CFL
E. 2CA3

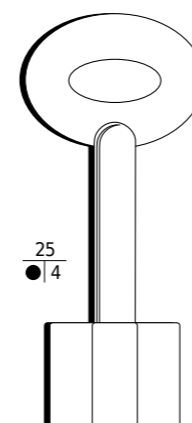

25
●/4

CEP9



S. CPC
E. 1C6
K. 1CER10

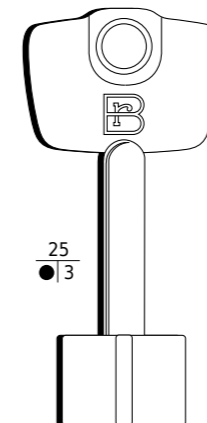

25
●/3

CEP12



S. CPXN
E. 1C9Q
K. 1CER12

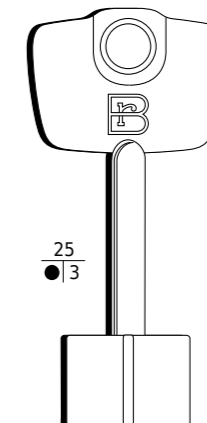

25
●/3

CEP22



S. 5C15
E. 1C20
K. 12CER

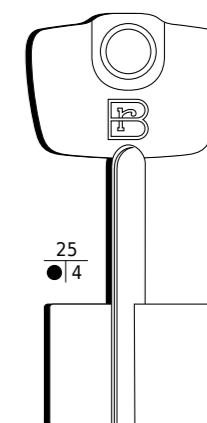

25
●/4

CE3



S. CCLQ
E. 1C15

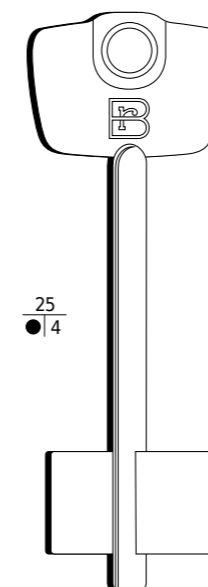

25
●/4

CE1



S. CQ
T. 1C2Q
K. 8CER

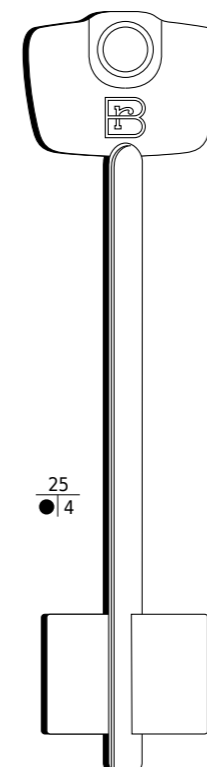

25
●/4

CE5



S. CLN
E. 2C21

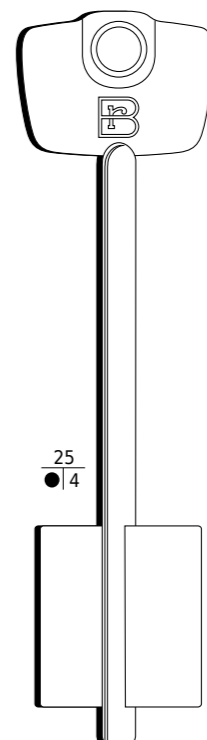

25
●/4

CE21



S. 5C11

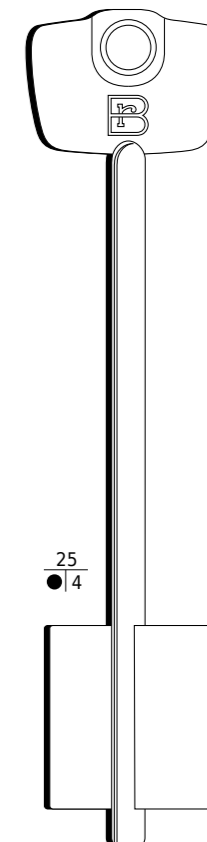

25
●/4

CE4



S. 5C9
E. 2C16
K. 1CER

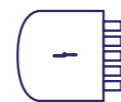

CERUTTI

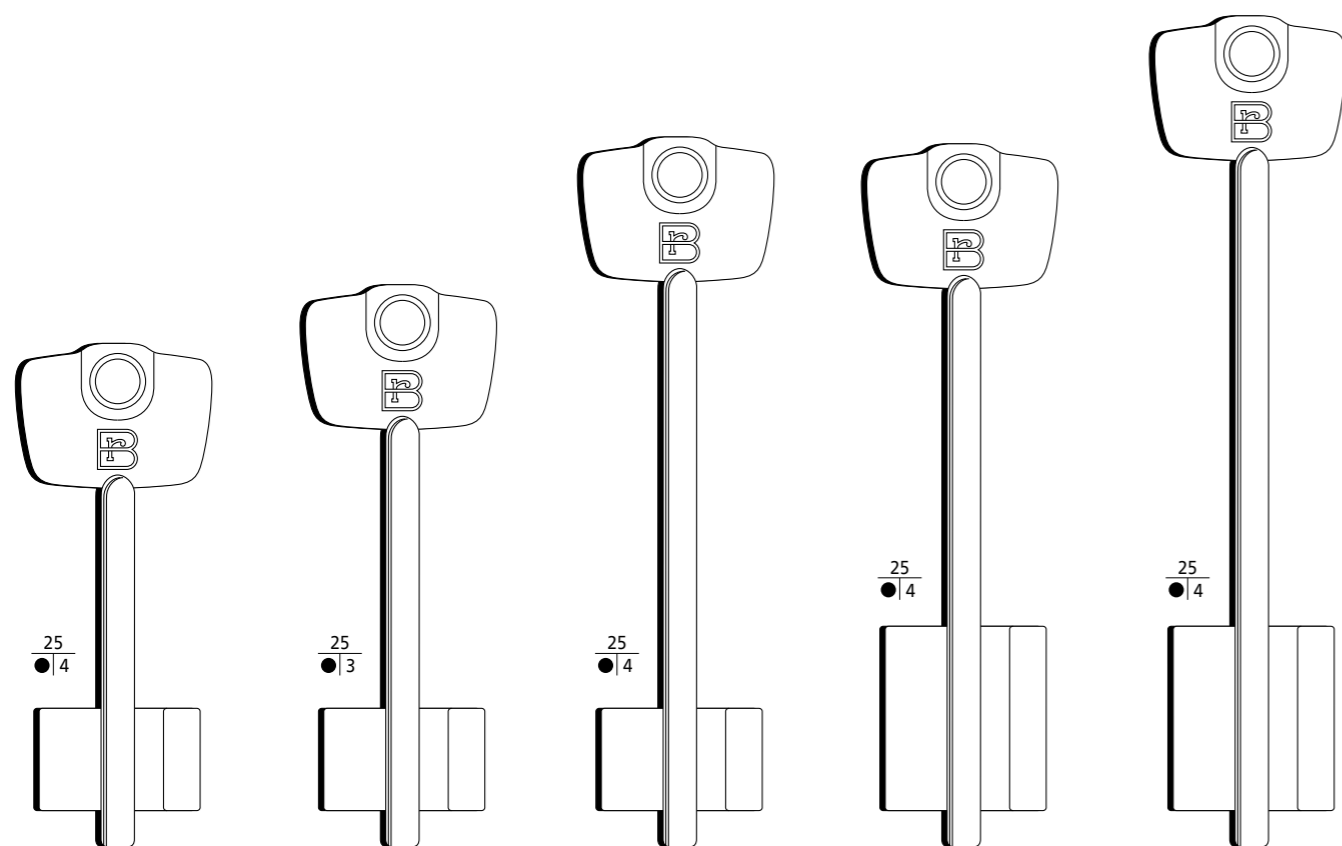

CE19

 S. 5C8
 E. 1C14

CE6

 S. CN
 E. 1C5
 K. 4CER

CE7

 S. CNC
 E. 1C5R
 K. 4CERS

CE20

 S. 5C14
 K. 1CER13

CE16

 S. 5C4
 E. 2C13
 K. 2CER16

CE14

 S. 5C6
 E. 2C11
 K. 10CER

CISA

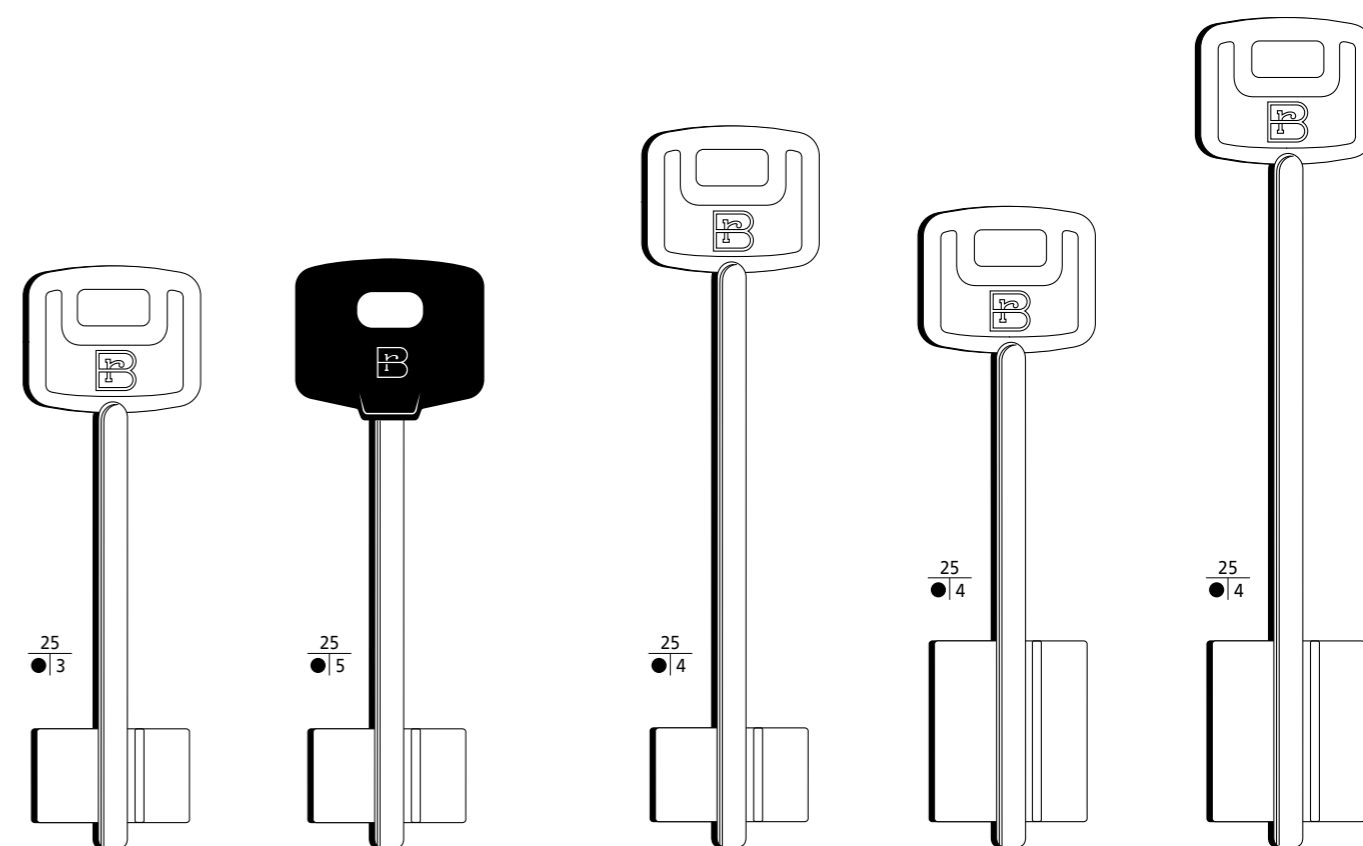

CS1

 S. CS
 T. 1C11
 K. 1CA

CS2

 S. CSC
 E. 1C11R
 K. 14CA

CS1P

 S. CSP
 E. 1C11P97
 K. 1CAP

CS5

 S. CSM
 E. 2C13
 K. 3CA

CS6

 S. CSMC
 E. 2C13R

CS10

 S. 5CS2
 E. 2C14
 K. 4CA

CS9

 S. 5CS1
 E. 2C14R
 K. 4CAS

CS4

 S. CSLC
 E. 2C12
 K. 2CA





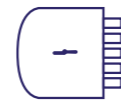



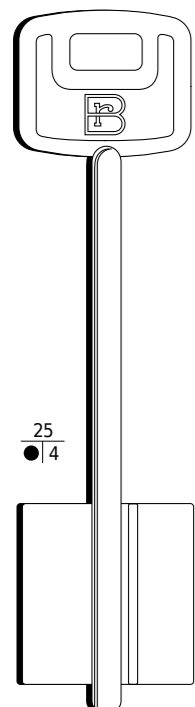
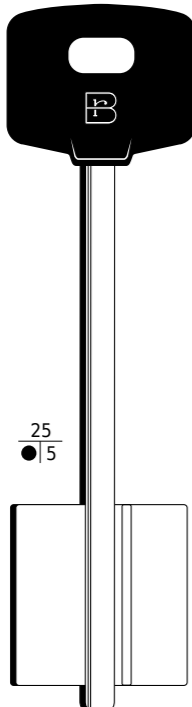
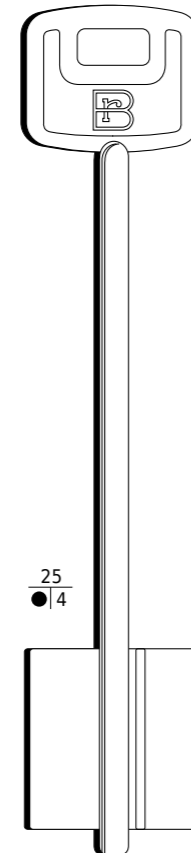
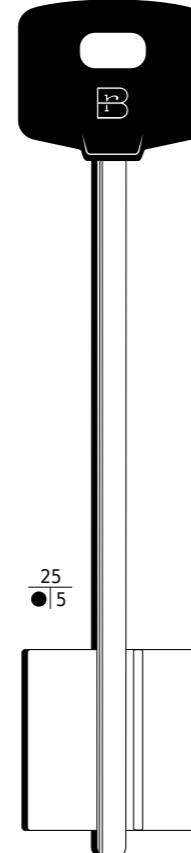
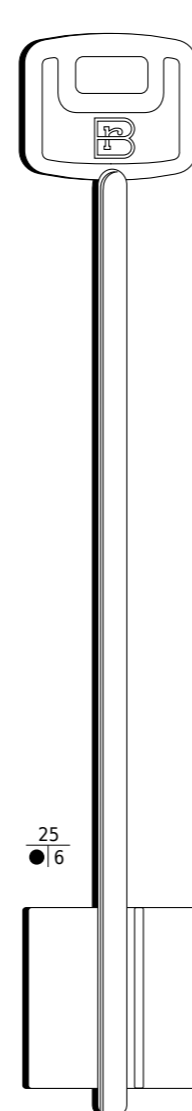
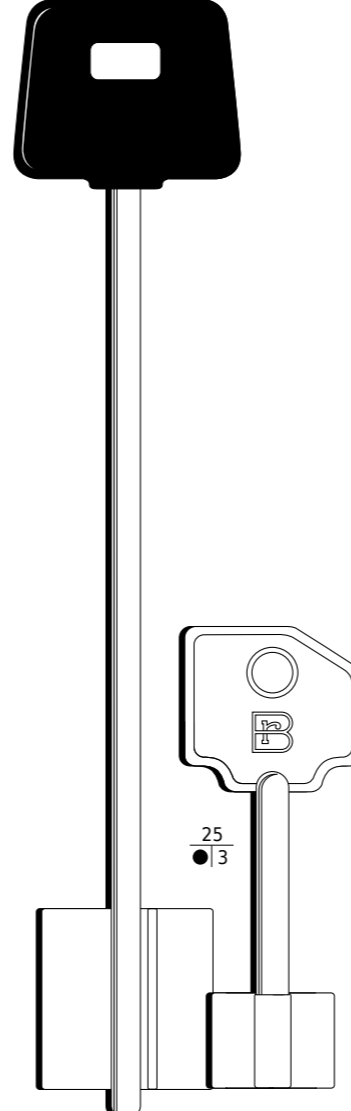
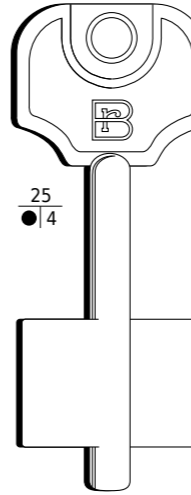
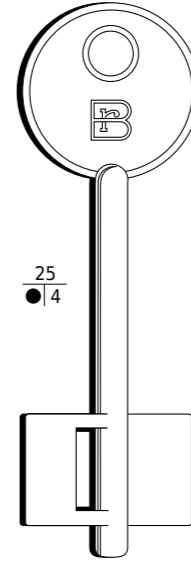
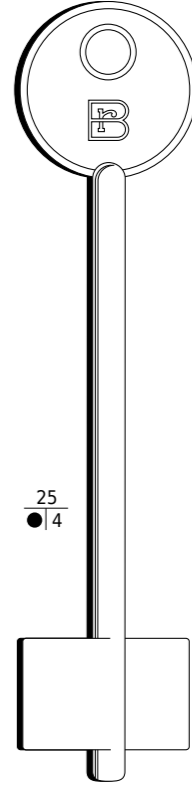
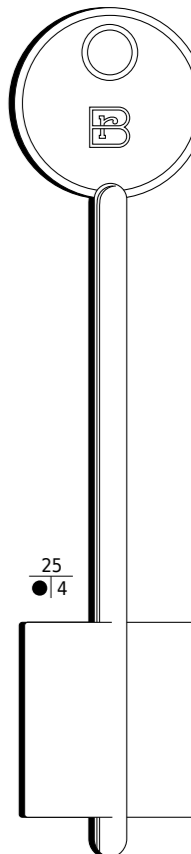

CS3

 S. CSL
 E. 2C12R
 K. 13CA



CISA

CR

| | | | | | | | | | |
|---|---|---|--|---|---|---|---|---|---|
|  |  |  |  |  |  |  |  |  |  |
| $\frac{25}{\bullet 4}$ | $\frac{25}{\bullet 5}$ | $\frac{25}{\bullet 4}$ | $\frac{25}{\bullet 5}$ | $\frac{25}{\bullet 6}$ | $\frac{25}{\bullet 3}$ | $\frac{25}{\bullet 4}$ | $\frac{25}{\bullet 4}$ | $\frac{25}{\bullet 4}$ | $\frac{25}{\bullet 4}$ |
| CSV15 | CSV15P | CSV16 | CSV16P | CSV17 | CRP21 | CR7 | CR11 | CR12 | CR2 |
|  |  |  |  |  |  |  |  |  |  |
| S. 5CS10 E. 2CI8 K. 2CA10 | S. 5CS10P E. 2CI8P97 K. 2CA10P | S. 5CS12 E. 2CI9 K. 2CA12 | S. 5CS12P E. 2CI9P97 K. 2CA12P | E. 2CI11 | S. 5R7 E. 1CR14 K. 7C | S. RN E. 1CR9 K. 2C6 | S. 5R2 E. 1CR10 K. 2C7 | S. RM E. 2CR8 K. 2C8 | S. RL E. 2CR4 |

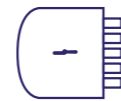

CR

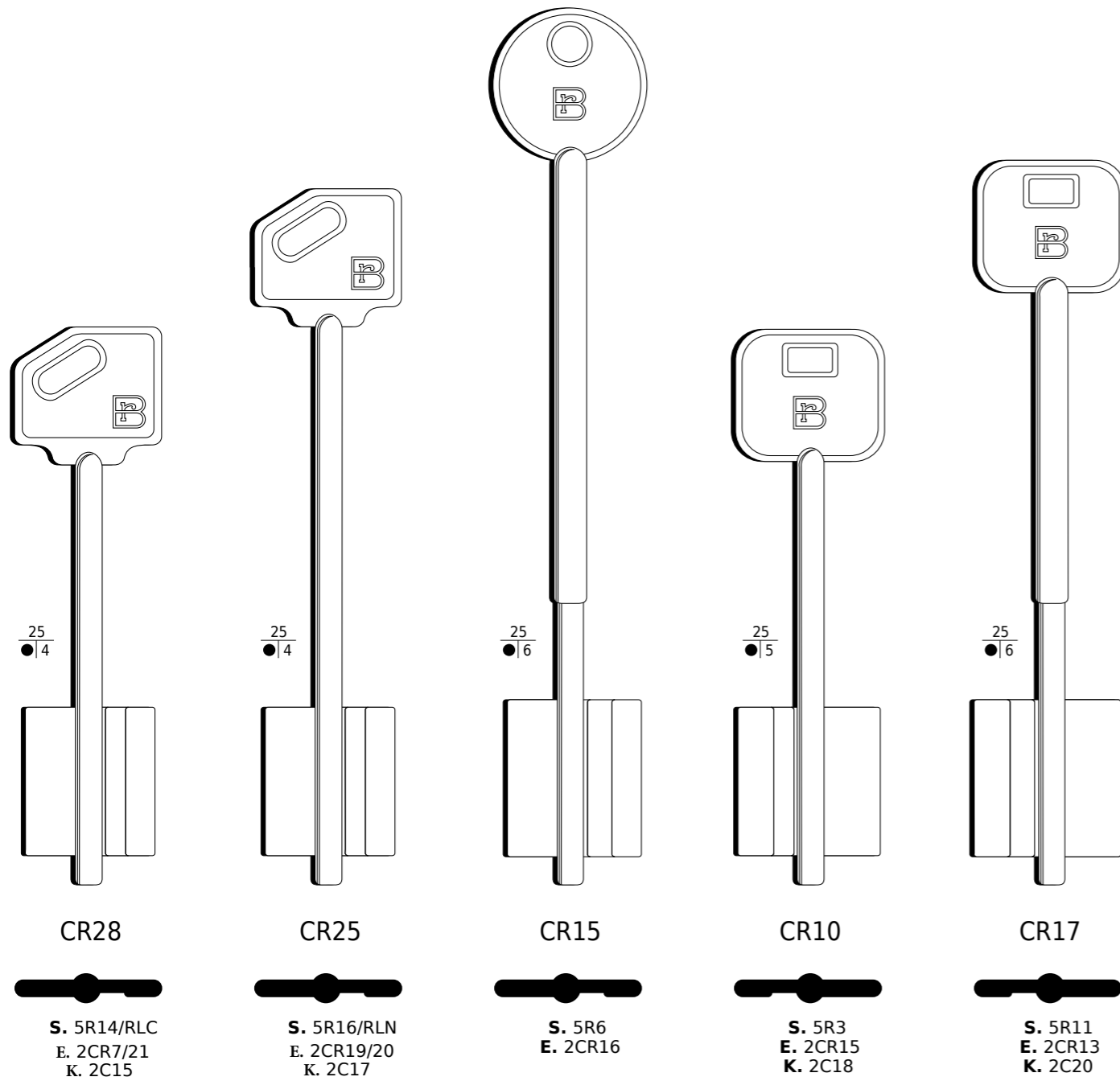

CR28

S. 5R14/RLC
E. 2CR7/21
K. 2C15

CR25

S. 5R16/RLN
E. 2CR19/20
K. 2C17

CR15

S. 5R6
E. 2CR16

CR10

S. 5R3
E. 2CR15
K. 2C18

CR17

S. 5R11
E. 2CR13
K. 2C20

CORBIN

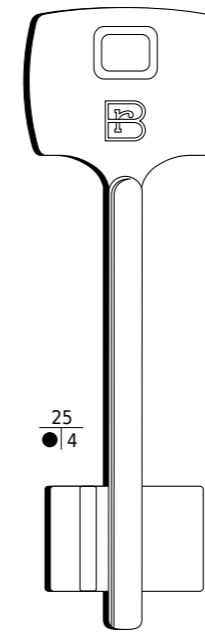

CB4

S. 5CB1

CB3

S. 5CB2

CIPIERRE

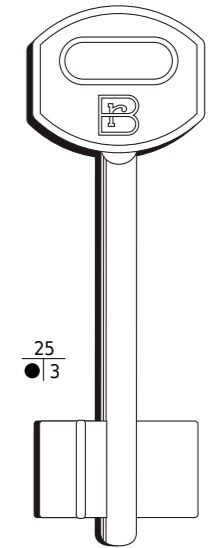

CPR1

S. 5CPR3
E. 1CPR2
K. 2CIP3

ELZETT

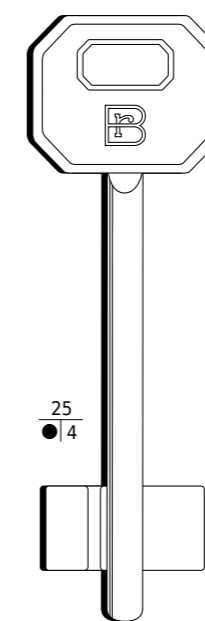

ELZ1

S. 5EL1
E. 2EZ1
K. 1ELZ1

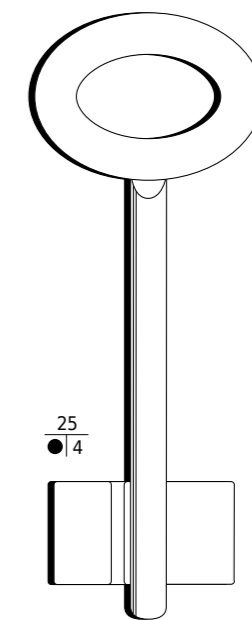

ELZ2

S. 7308E
E. 2EZ3
K. 1ELZ2

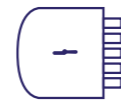

ESETY

ESETY

FACEF - DOMUS

ES17
S. 5EY20
E. 2ES12
K. 20EY

ES19
S. 5EY24

ES21
S. 5EY22
E. 2ES13
K. 22EY

ES22
S. 5EY32
E. 2ES15

ESP4
S. EPN
E. 1ES4

ES1
S. E

ES7
S. EN
E. 2ES7
K. 2TE2

ES10
S. 5EY5
E. 2ES8
K. 2EY5

ES2
S. EL
E. 2ES2
K. 2EY

ES11
S. 5EY3
E. 2ES9
K. 1EY3

ES9
S. 5EY1
E. 2ES10

DO2
S. FD

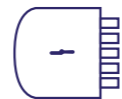

FEB

FERRAMETALL

FIAM

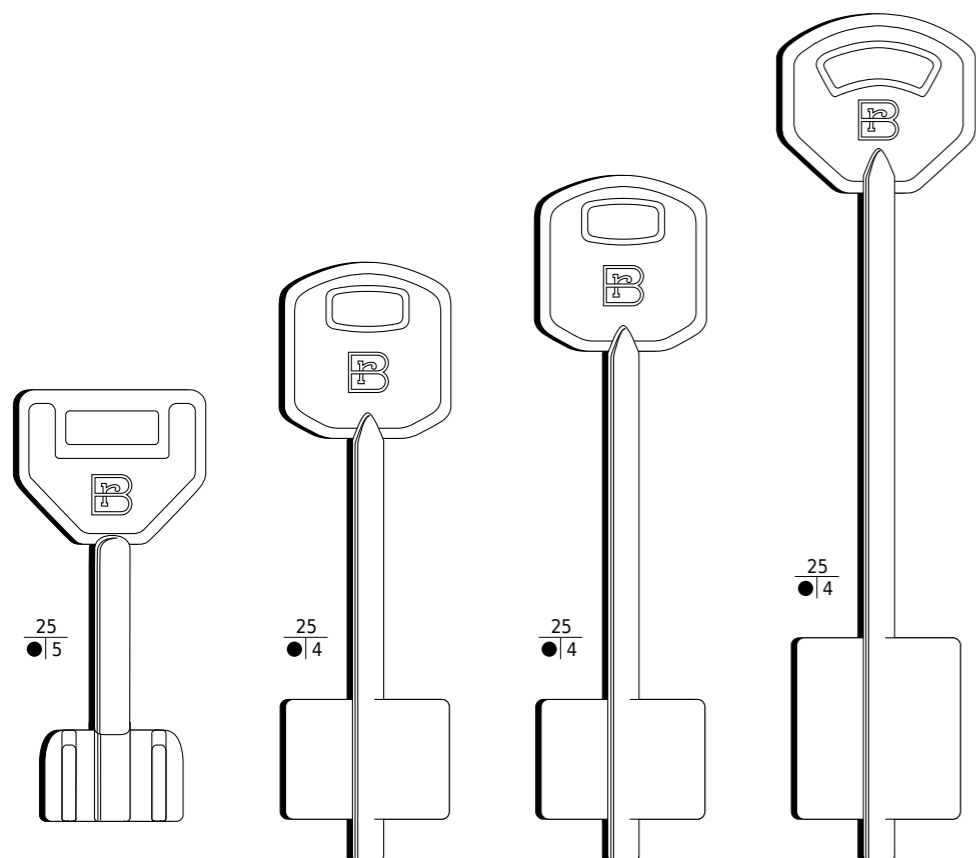

FEP2



S. 5FEB5
E. 1FEB3
K. 3FEB

FE1



S. 5FEB1
E. 2FEB1
K. 1FEB

FE5



S. 5FEB7
E. 2FEB4
K. 7FEB

FE3



S. 5FEB3
E. 2FEB2

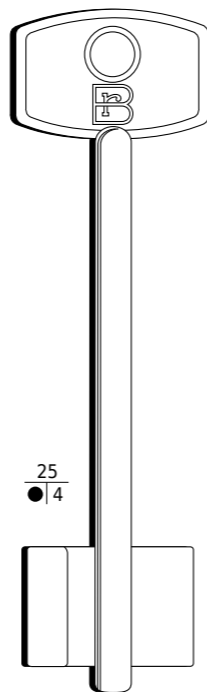

FM1



S. 5FR1

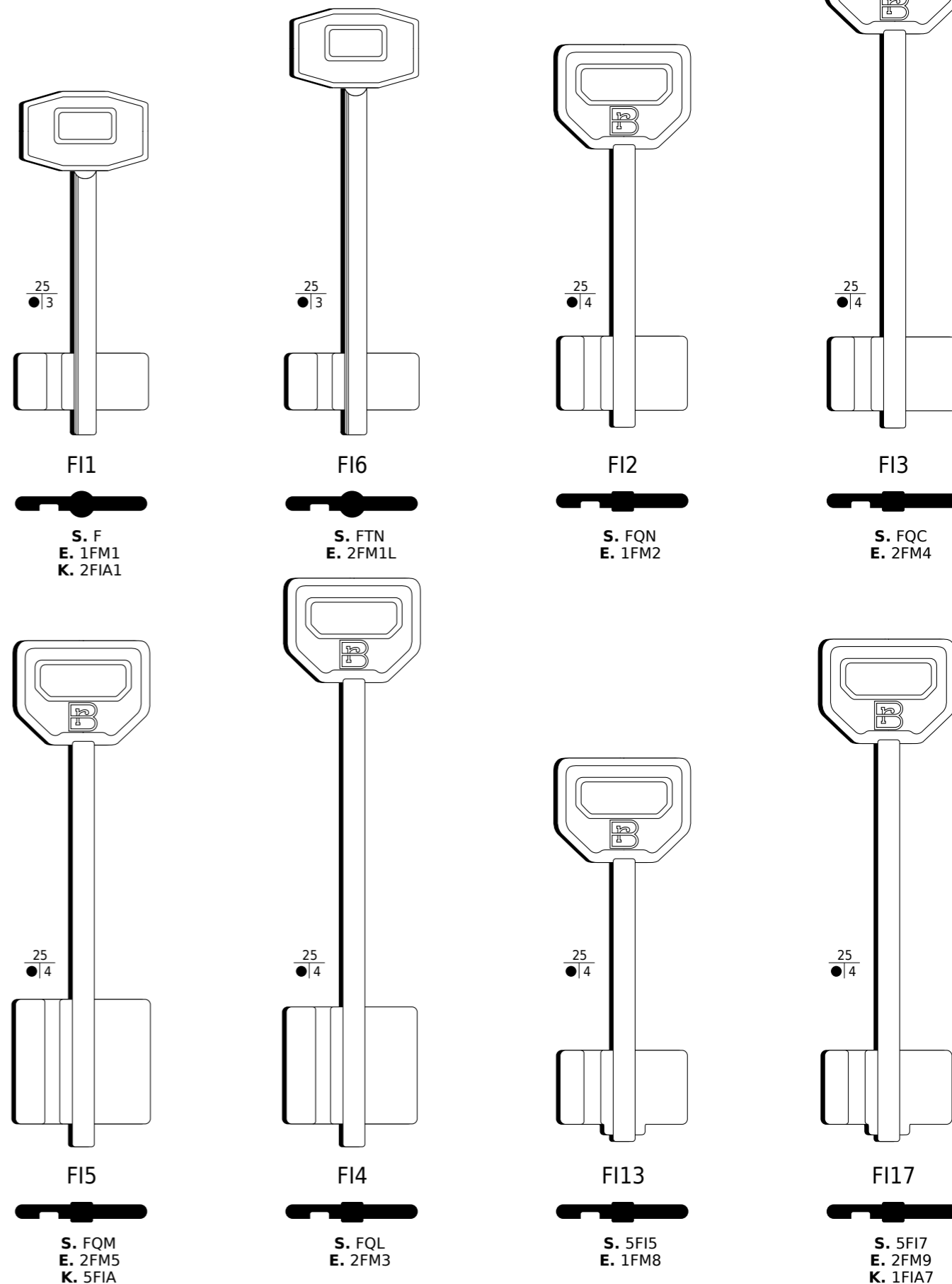

FI1



S. F
E. 1FM1
K. 2FIA1

FI6



S. FTN
E. 2FM1L

FI2



S. FQN
E. 1FM2

FI3



S. FQC
E. 2FM4

FI5



S. FQM
E. 2FM5
K. 5FIA

FI4



S. FQL
E. 2FM3

FI13



S. 5FI5
E. 1FM8

FI17



S. 5FI7
E. 2FM9
K. 1FIA7

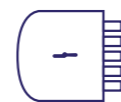

FIAM

FIAM

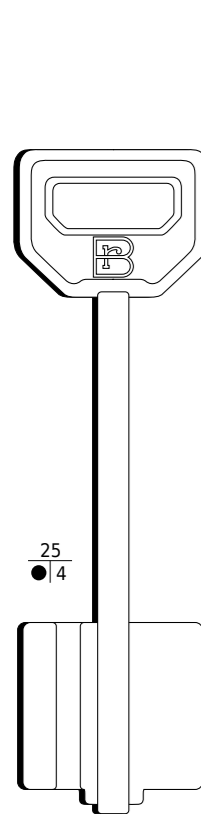

FI15



S. 5FI9
E. 2FM10
K. 15FIA

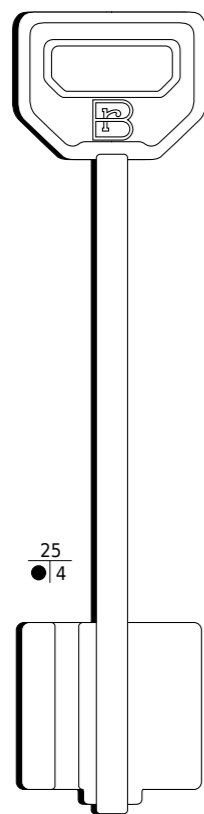

FI19



E. 2FM16

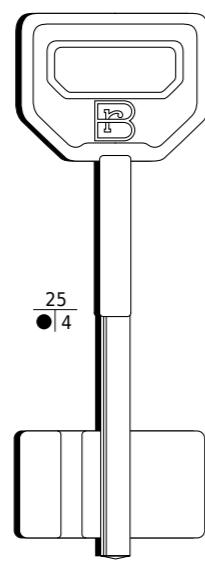

FI20



S. 5FI15
E. 1FM19
K. 2FIA24

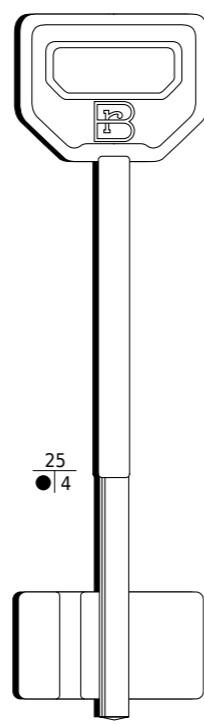

FI21



S. 5FI17
E. 2FM18
K. 1FIA17

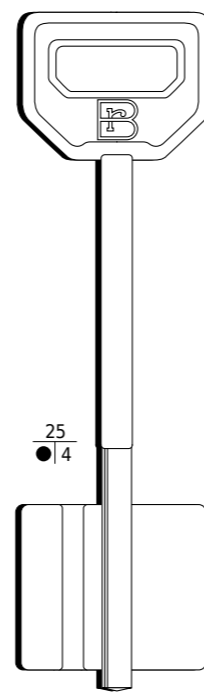

FI22



S. 5FI19
E. 2FM14
K. 1FIA19

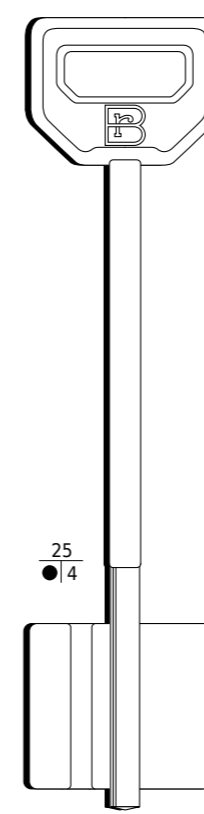

FI23



S. 5FI21
E. 2FM15
K. 2FIA27

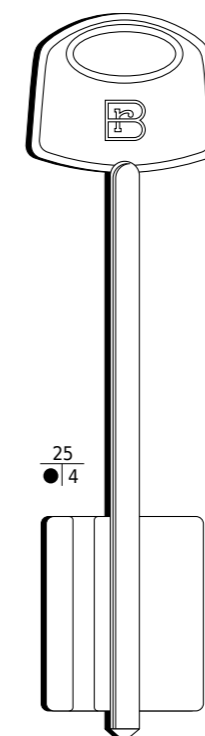

FI30



E. 2FM21

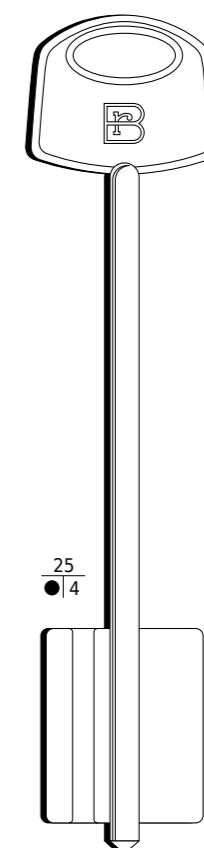

FI31



S. 5FI23
E. 2FM20
K. 1FIA5

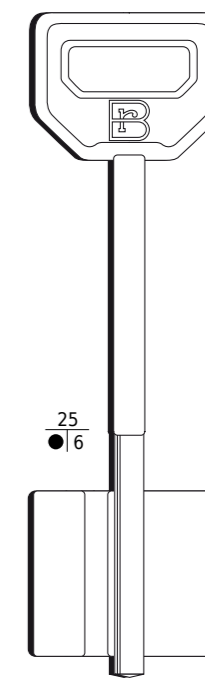

FI25V



E. 2FM17

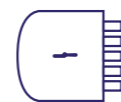

FICHET

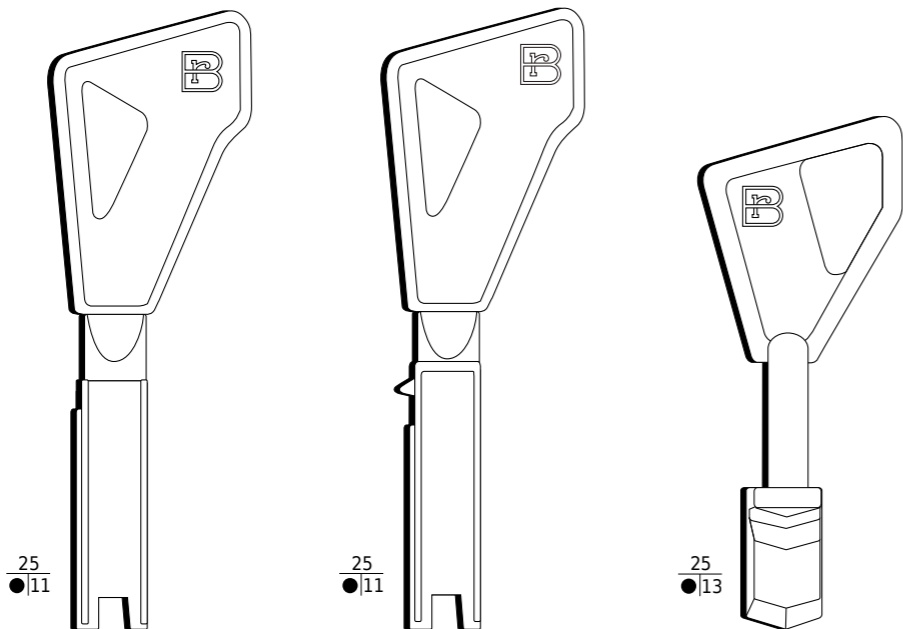

FCT45

S. FT500
E. FC6

FCT48

S. FT510
E. FC11

FCT777

S. FT525
E. FC14
K. FIC7

GMG

G.P.S. GIPIS

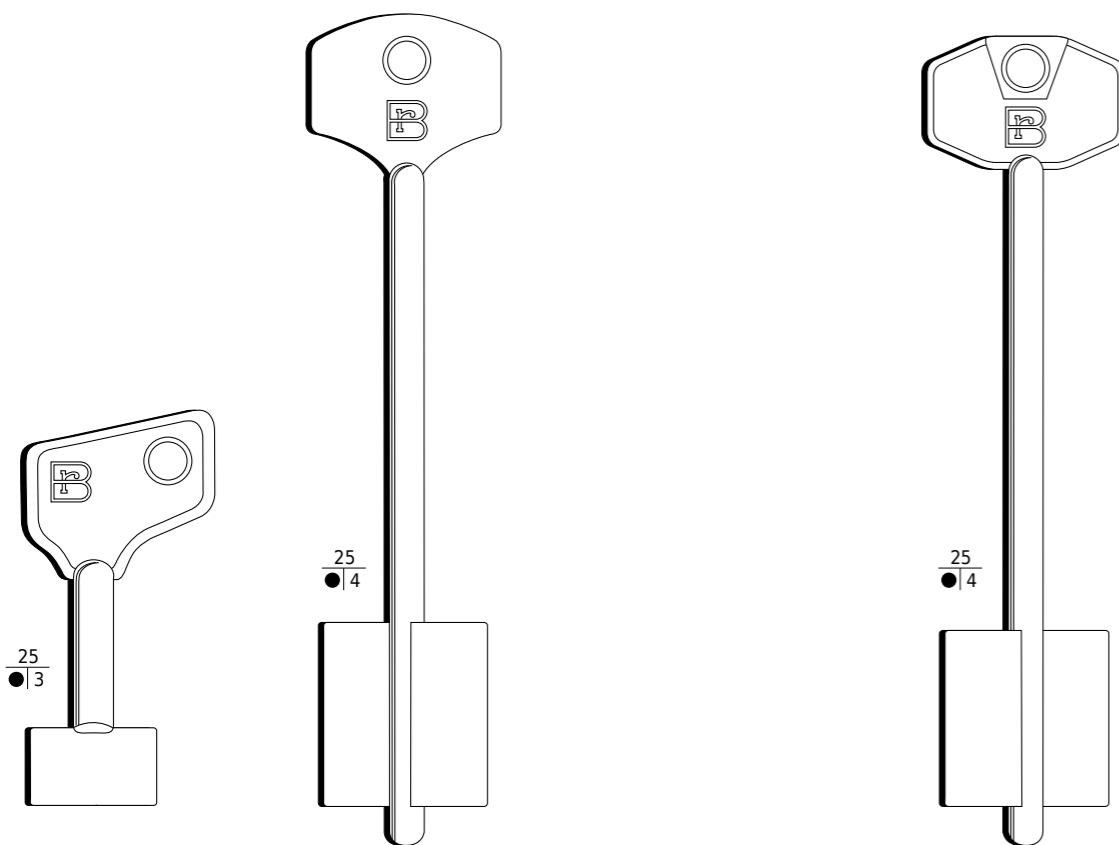

GMP3

S. GP

GM1

S. GL
E. 2GMG3
K. 2GM1

GP2

S. GIL

IDM

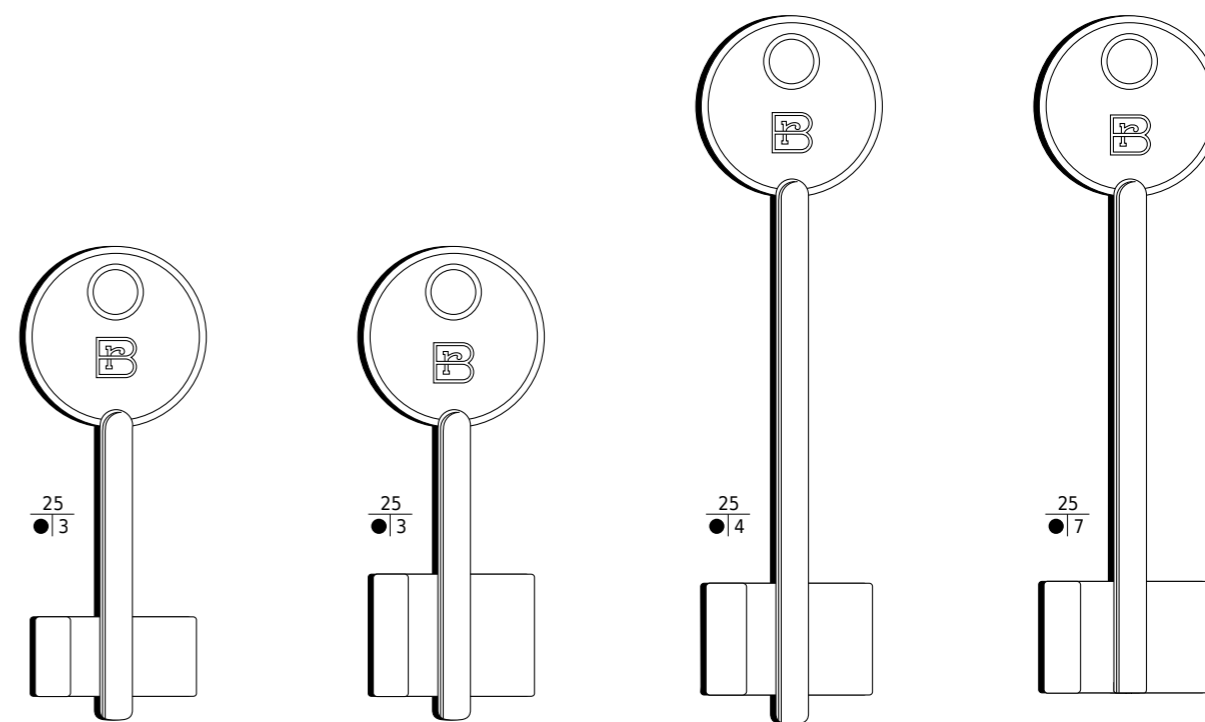

ID5

S. 5ID5
E. 1ID5
K. 2IDM2

ID1

S. 5ID7
E. 1ID6
K. 5IDM

ID2

S. IDM
E. 2ID2
K. 2IDM4





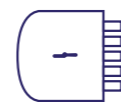



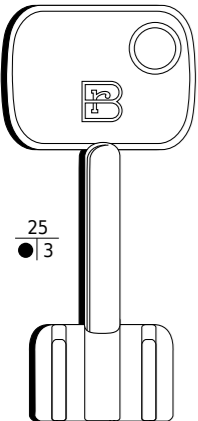
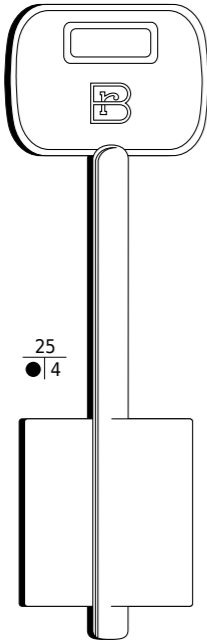
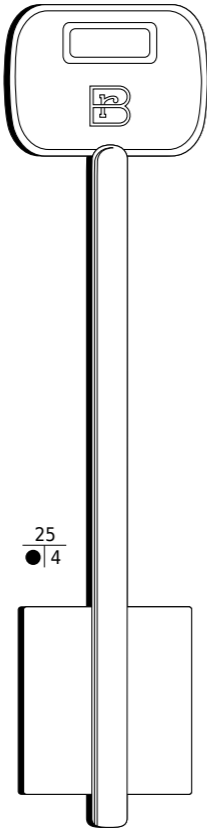
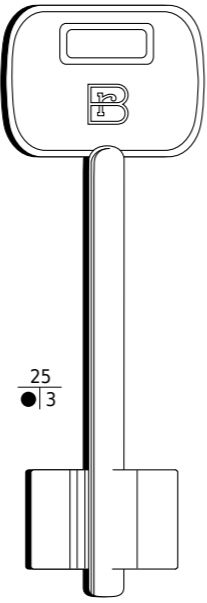
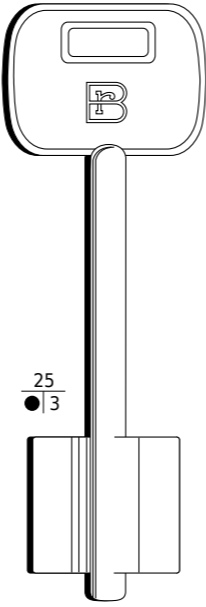
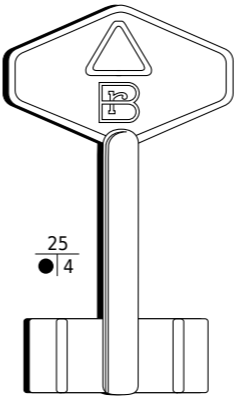
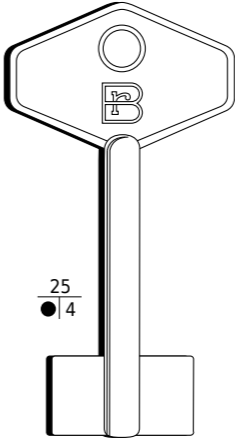
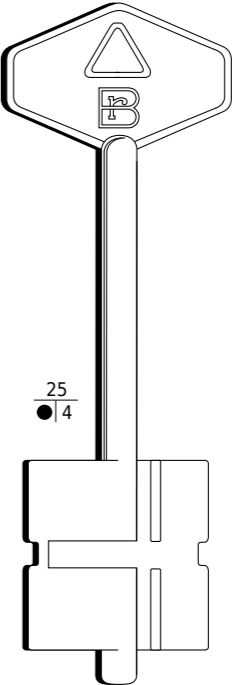
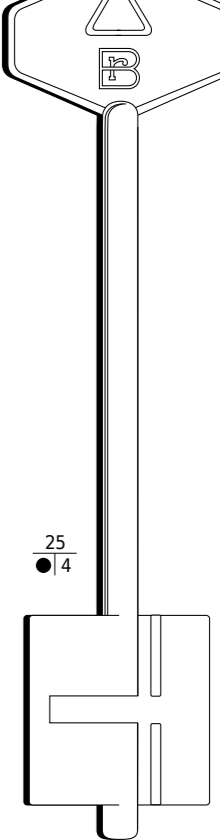

IDF19











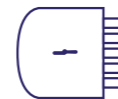



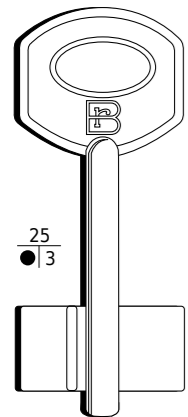

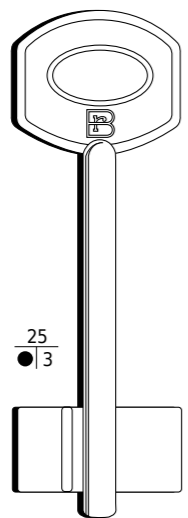

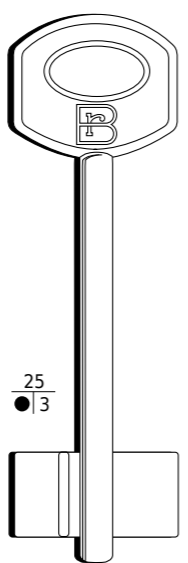

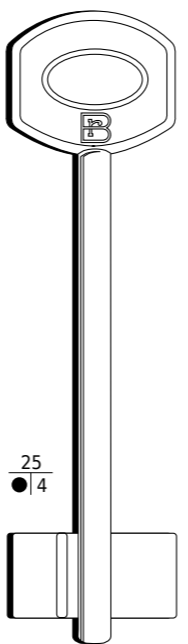
ISEO

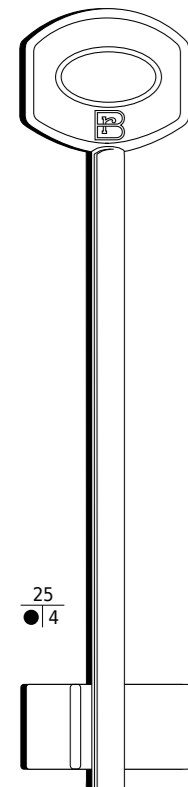
ITAL

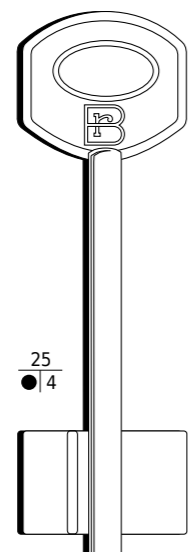

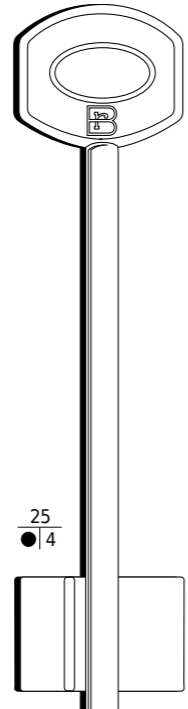

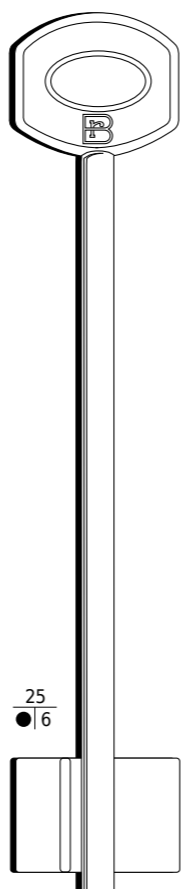





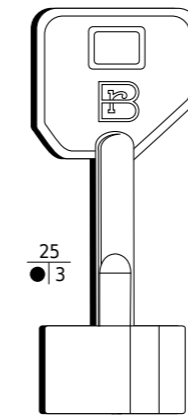

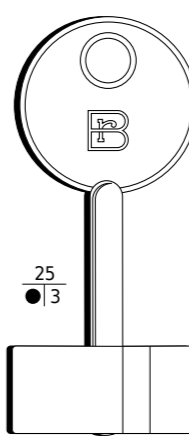
| | | | | | | | | |
|---|---|---|--|---|---|---|---|---|
|  |  |  |  |  |  |  |  |  |
| $\frac{25}{\bullet 3}$ | $\frac{25}{\bullet 4}$ | $\frac{25}{\bullet 4}$ | $\frac{25}{\bullet 3}$ | $\frac{25}{\bullet 3}$ | $\frac{25}{\bullet 4}$ | $\frac{25}{\bullet 4}$ | $\frac{25}{\bullet 4}$ | $\frac{25}{\bullet 4}$ |
| ISP5 | AU3 | IS7 | IS1 | IS3 | ITP4 | ITP5 | IT3 | IT2 |
|  |  |  |  |  |  |  |  |  |
| S. 5IE5 E. 1IE1 K. 4ISE | S. 5IE1 E. 2IE2 | S. 5IE3 E. 2IE3 | S. 5IE11 E. 1IE6 K. 2ISE7 | S. 5IE9 E. 1IE5 K. 3ISE | E. 1IT7 K. 4IT | S. 5IT3 E. 1IT1 K. 3IT | S. 5IT6 E. 2IT5 | S. 5IT8 E. 2IT4 K. 2IT8 |

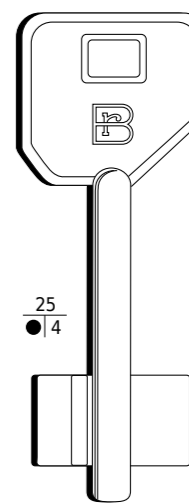

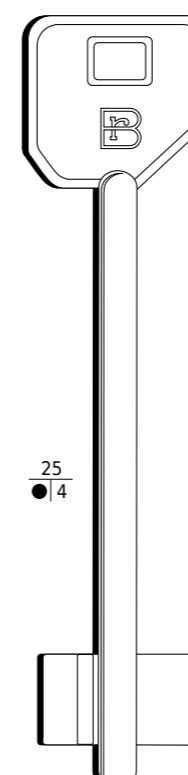
JUWEL

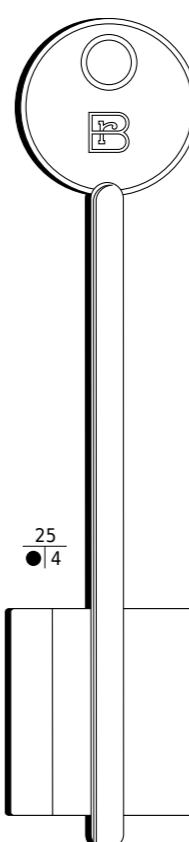
| | | | | | |
|---|---|---|---|---|--|
|  $\frac{25}{\bullet 3}$ JW1  S. JW20 E. 1J1 |  $\frac{25}{\bullet 3}$ JW2  S. JW35 E. 1J2 K. 2JW |  $\frac{25}{\bullet 3}$ JW6  S. JW40 E. 1J4 K. 6JW |  $\frac{25}{\bullet 4}$ JW4  S. JW50 E. 2J7 K. 3JW | | |
| $\frac{25}{\bullet 7}$ JWF2  | |  $\frac{25}{\bullet 4}$ JW8  S. JW70 E. 2J6 K. 7JW |  $\frac{25}{\bullet 4}$ JW10  S. 5JW1 E. 1J5 K. 10JW |  $\frac{25}{\bullet 4}$ JW9  S. JW90 E. 2J8 K. 9JW |  $\frac{25}{\bullet 6}$ JW7  E. 2J9 |

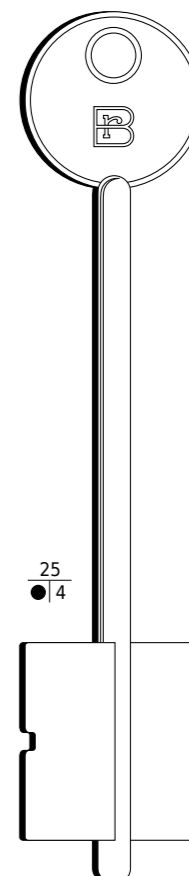
KASSEL

| | | |
|--|---|--|
|  $\frac{25}{\bullet 3}$ KLP4  S. 5KY6 E. 1KA8 K. 4KEL |  $\frac{25}{\bullet 3}$ KLP7  S. 5KY2 E. 1KA4 K. KEL |  $\frac{25}{\bullet 4}$ KL5  S. 5KY7 E. 1KA9 K. 2KEL |
|  $\frac{25}{\bullet 4}$ KL6  E. 2KA10 |  $\frac{25}{\bullet 4}$ KL3  S. KYL |  $\frac{25}{\bullet 4}$ KL2  S. KL E. 2KA2 K. 6KEL |

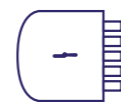

MOIA

MOTTURA

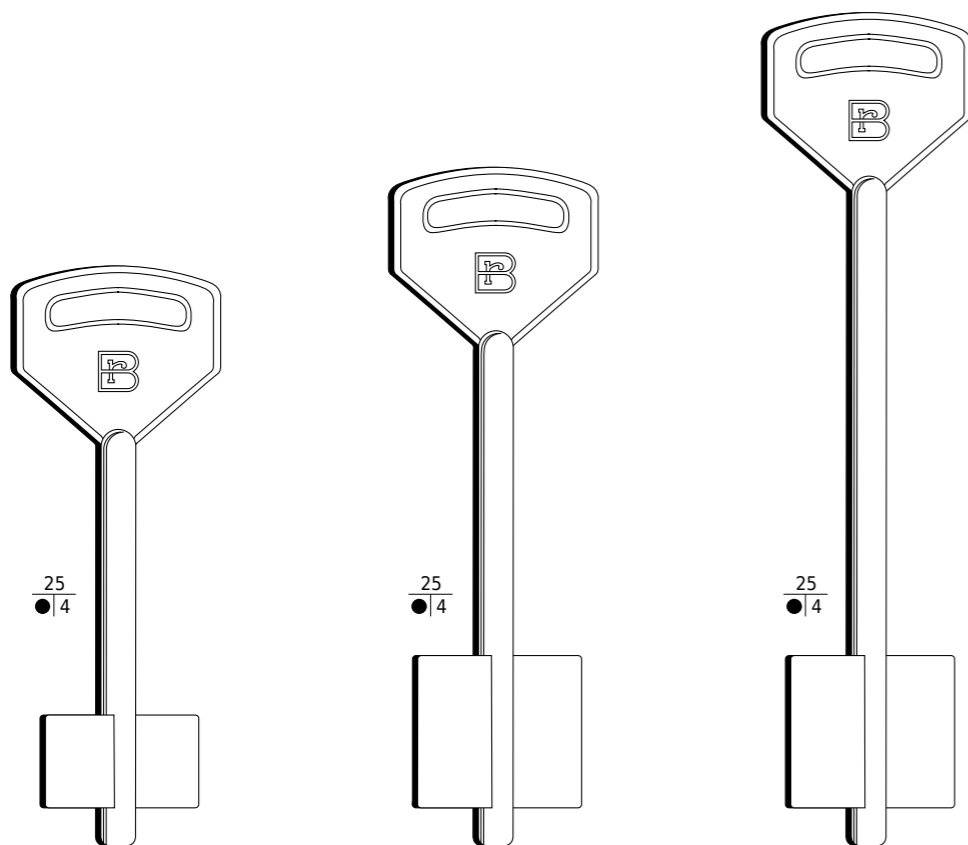

MO3



S. MC
E. 1MA2

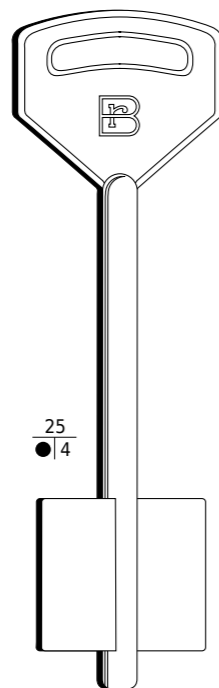

MO5



S. 5MO2
E. 2MA3
K. 2MOI2

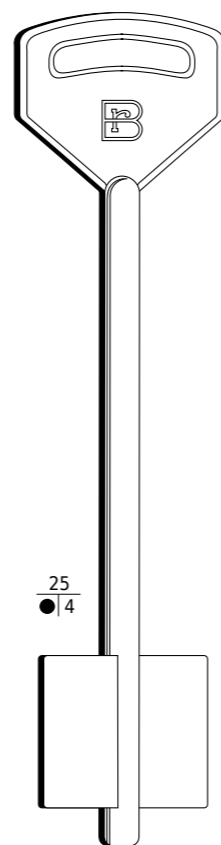

MO1



S. ML
E. 2MA1
K. 2MOI1

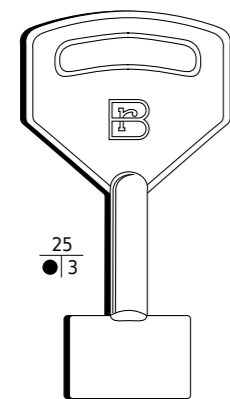

MOP2



S. PP
E. 1MA
K. 1MOI1

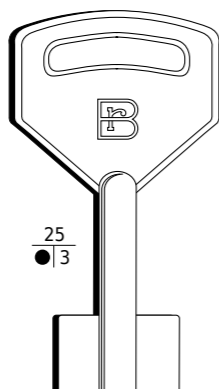

MOP6



E. 1MA4

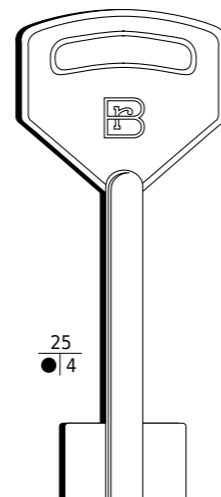

MOP7



E. 1MA5
K. 2MOI3

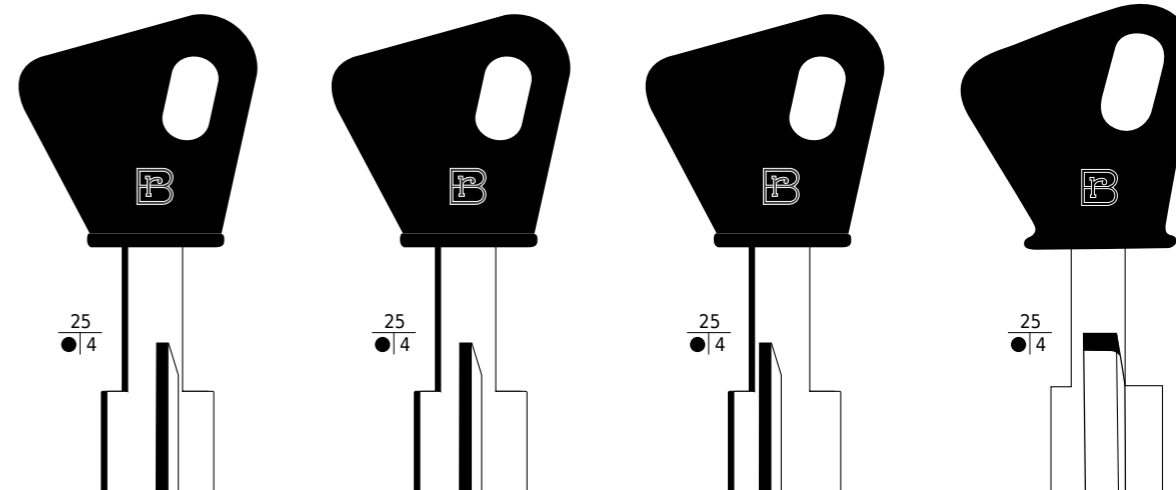

MTAP



S. MT4P
E. MO5P59
K. MOAP

MTGP



S. MT4RP
E. MO5RP59
K. MOGP

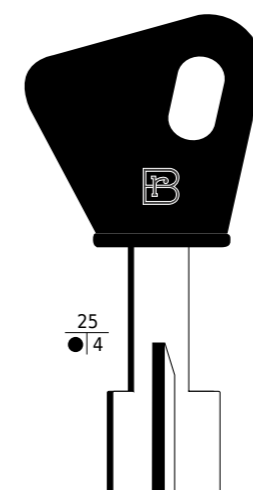

MTCP



S. MT3P
E. MO2P59
K. MOCP

MTFP



S. MT3RP
E. MO2RP59
K. MOFP

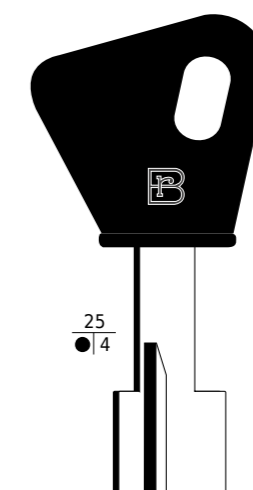

MTEP



S. MT2P
E. MO1P59
K. MOEP

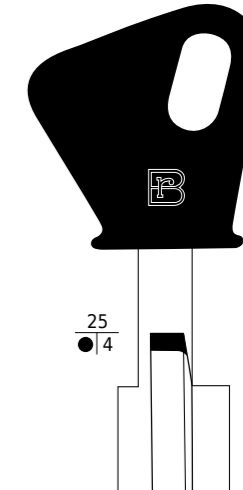

MTUP

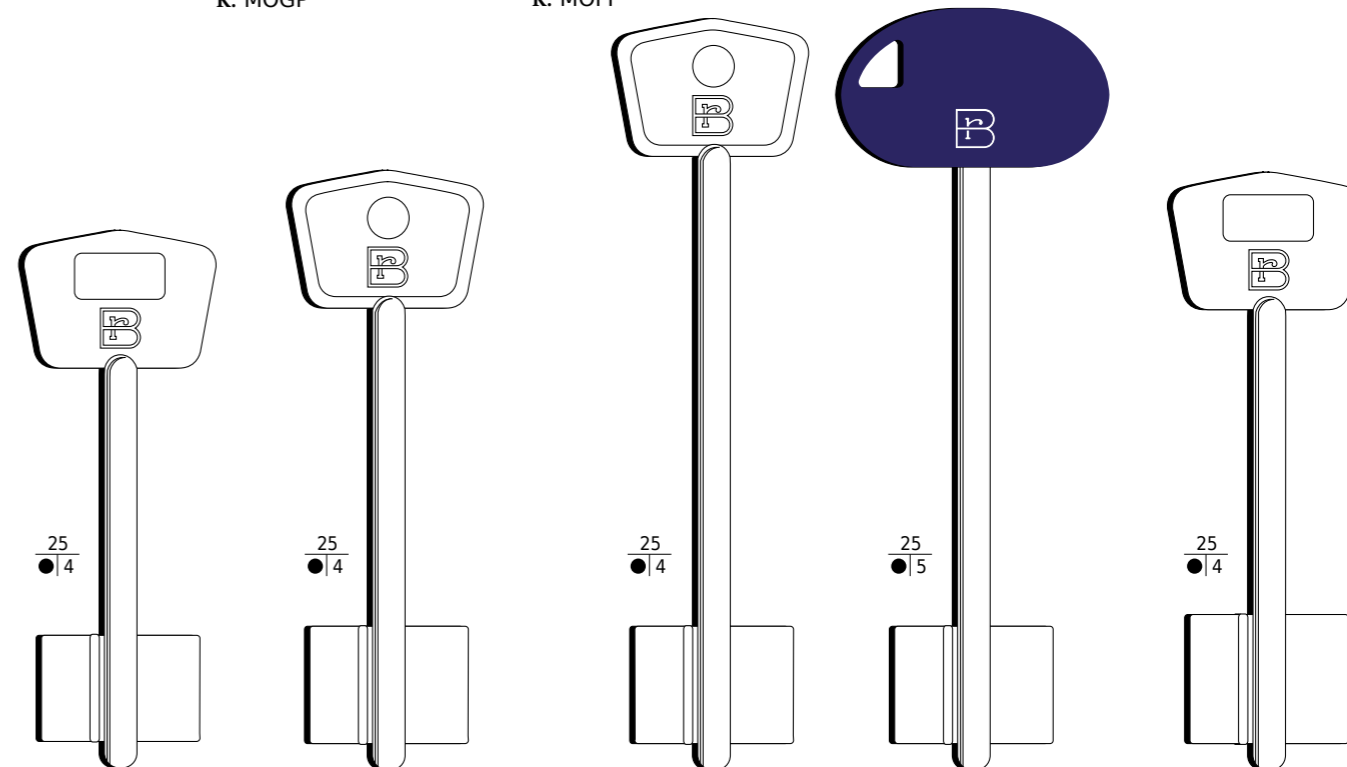

MT10



S. 5MT3
E. 1MO6
K. 15MOP

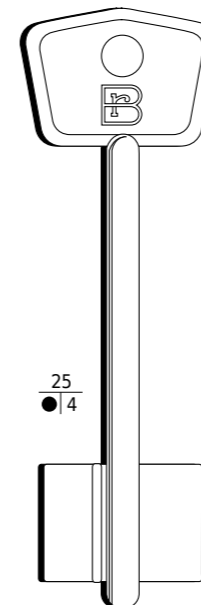

MT22

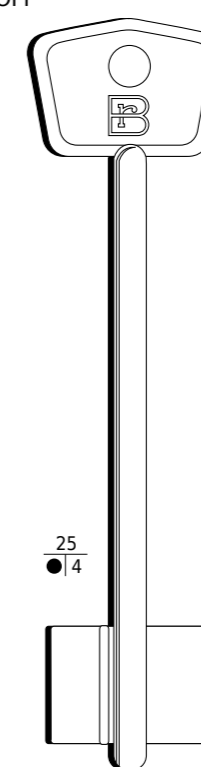

MT24



S. 5MT21
E. 2MO25
K. 2MO10

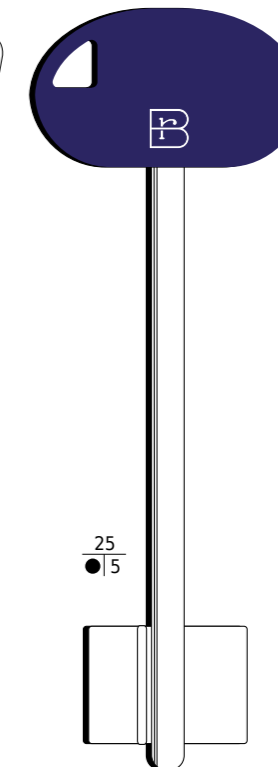

MT24P



S. 5MT21BP
E. 2MO25P165
K. 2MO10P

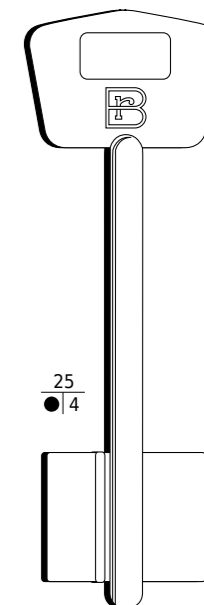

MT14





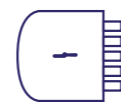





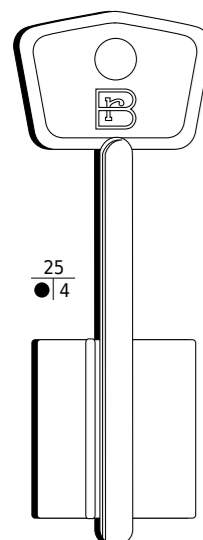
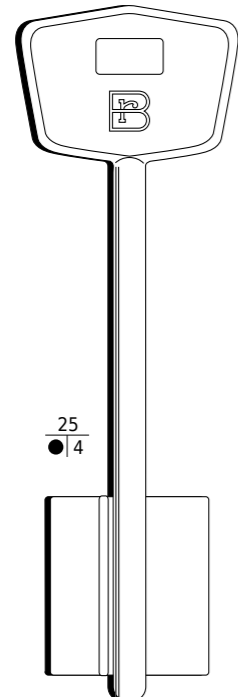
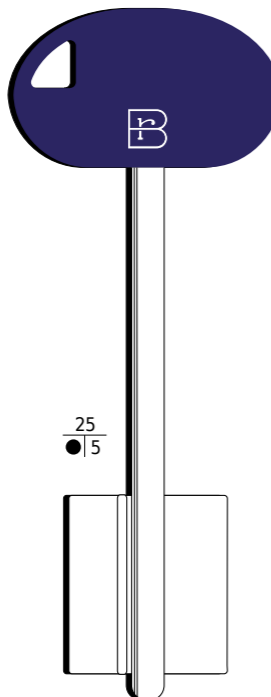
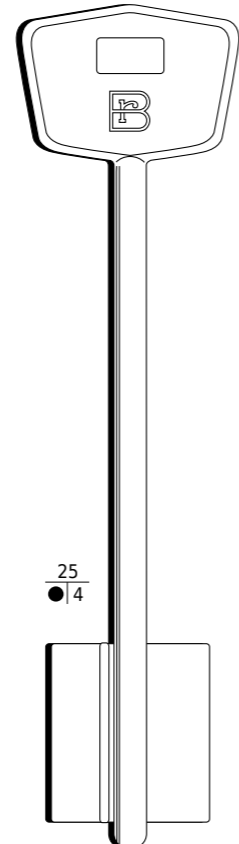
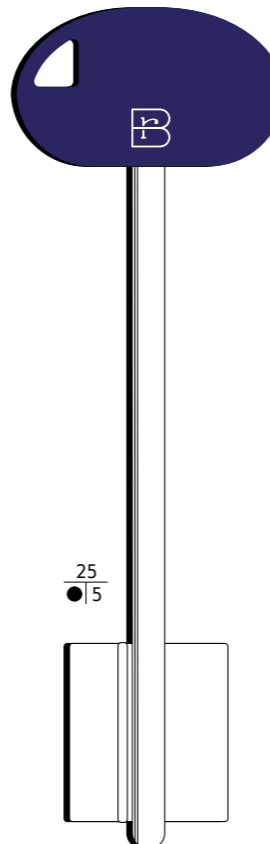
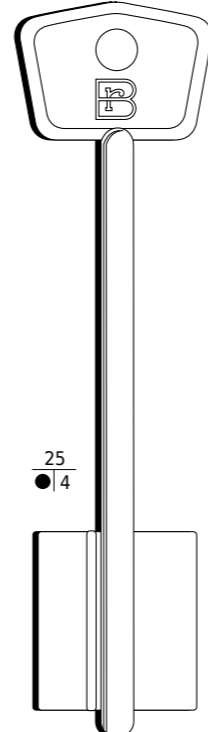
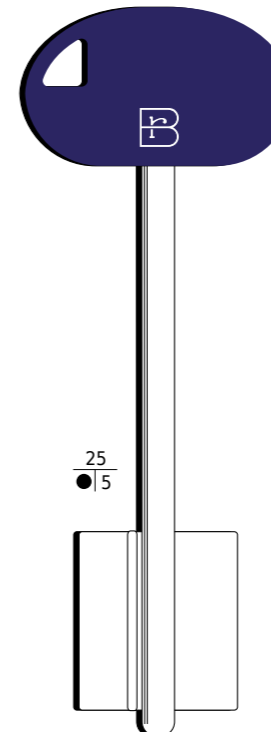
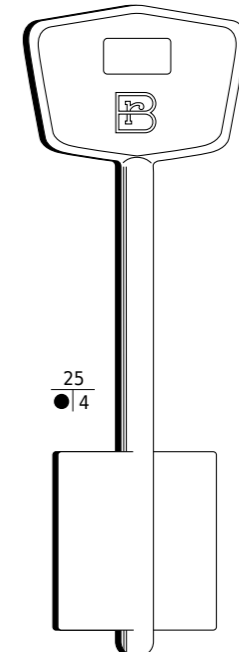
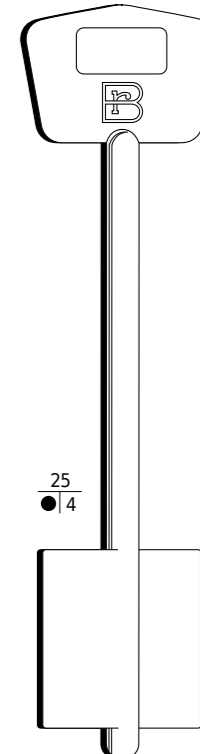





S. 5MT7
E. 2MO9R
K. 2MO14P



MOTTURA

MOTTURA

| | | | | | | | | |
|---|---|---|--|---|---|---|---|---|
|  |  |  |  |  |  |  |  |  |
| $\frac{25}{\bullet 4}$ | $\frac{25}{\bullet 4}$ | $\frac{25}{\bullet 5}$ | $\frac{25}{\bullet 4}$ | $\frac{25}{\bullet 5}$ | $\frac{25}{\bullet 4}$ | $\frac{25}{\bullet 5}$ | $\frac{25}{\bullet 4}$ | $\frac{25}{\bullet 4}$ |
| MT6 | MT8 | MT8P | MT4 | MT4P | MT15 | MT15P | MT17 | MT19 |
|  |  |  |  |  |  |  |  |  |
| E. 1MO22 | S. 5MT5 E. 2MO7 K. 5MO | S. 5MT5BP E. 2MO7P165 K. 5MOP | S. MTNC T. 2MO8QR K. 17MO | S. MTNCBP E. 2MO8RP165 K. 17MOP | S. 5MT9 T. 2MO10R K. 18MO | S. 5MT9BP E. 2MO10RP165 K. 18MOP | S. 5MT14 E. 2MO19 K. 19MO | S. 5MT16 E. 2MO20 K. 2MO20 |
| | MT9 | | MT3 | MT3P | MT16 | | | |
| |  | |  |  |  | | | |
| | K. 6MOP | | S. MTN E. 2MO8 K. 16MO | S. MTNBP E. 2MO8P165 K. 16MOP | S. 5MT10 E. 2MO10 | | | |

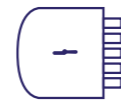

MOTTURA

POTENT

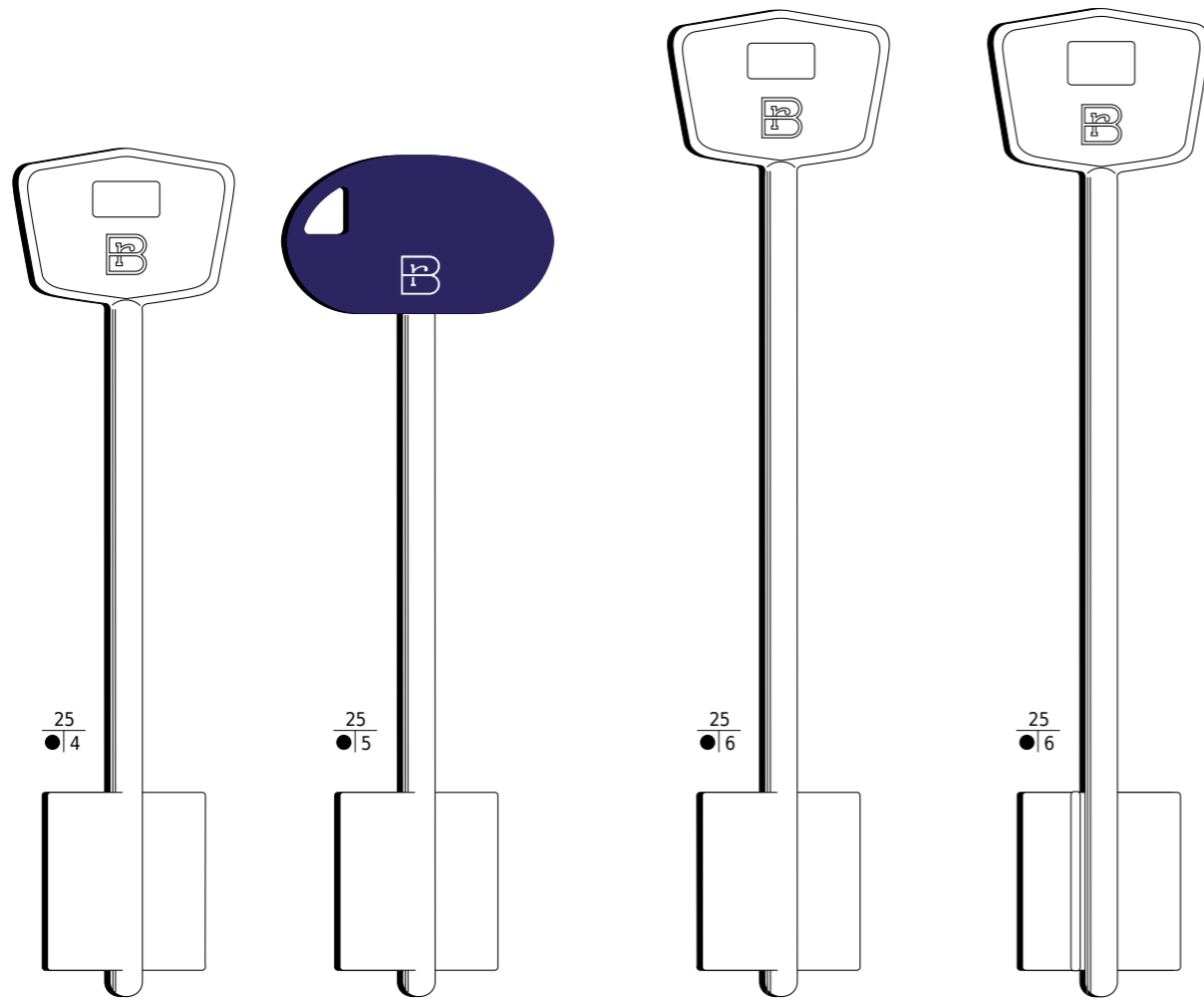

MT21

MT21P

MT11

MT12



S. MTL
E. 2MO4
K. 2MO



S. MTLBP



S. 5MT18
E. 2MO23
K. 2MO13P



S. 5MT19
E. 2MO24
K. 2MO12P

MT13



E. 2MO24R
K. 2MO15P

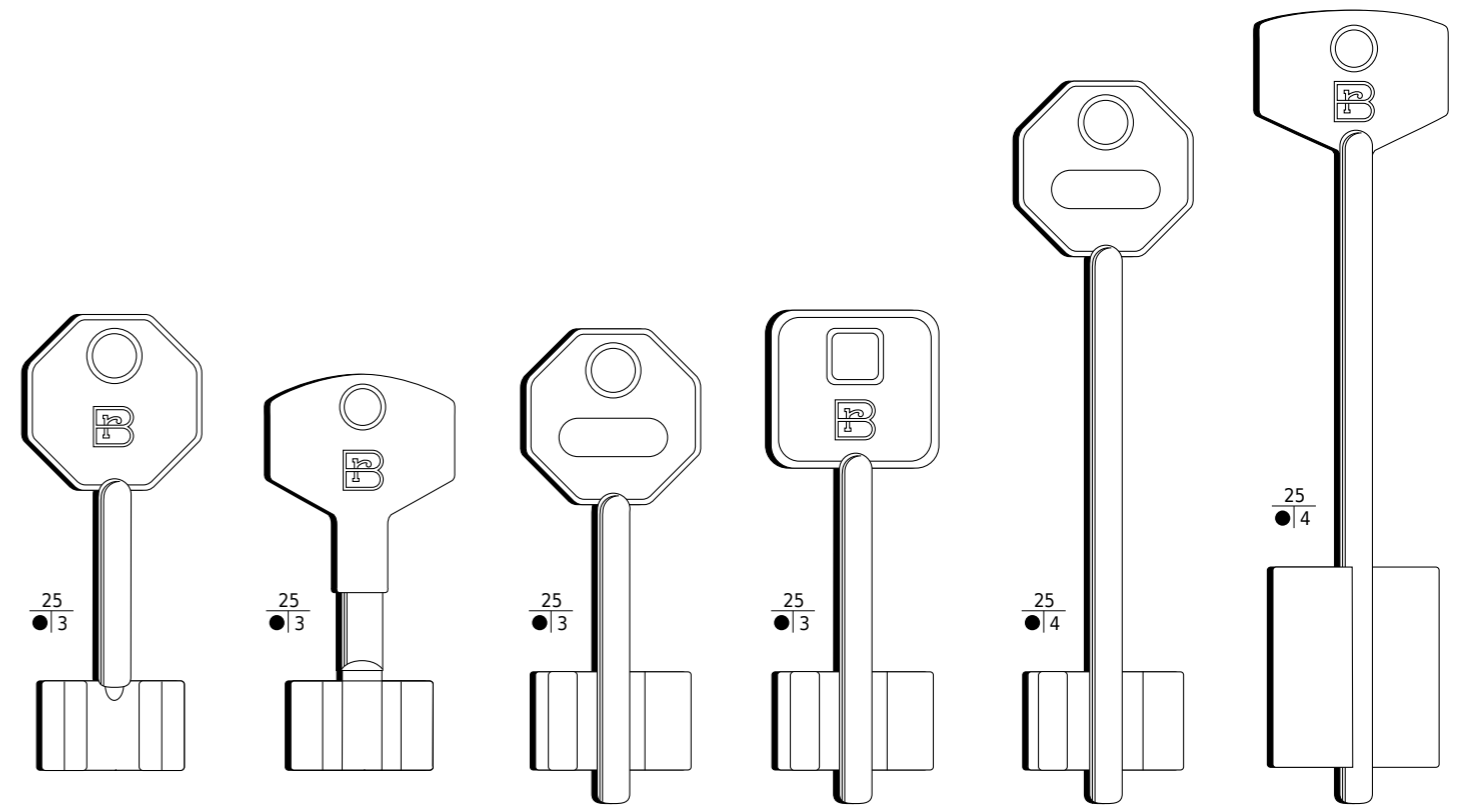

POP11

POP5

PO6

PO15

PO17

PO1



S. 5PT11
E. 1PN12
K. 10PO



S. POP
E. 1PN2
K. 1PO



S. 5PT13
E. 1PN6
K. 2PO13



S. 5PT21
E. 1PN13



S. 5PT15
E. 2PN14



S. PL
E. 2PN3

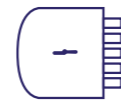

POTENT

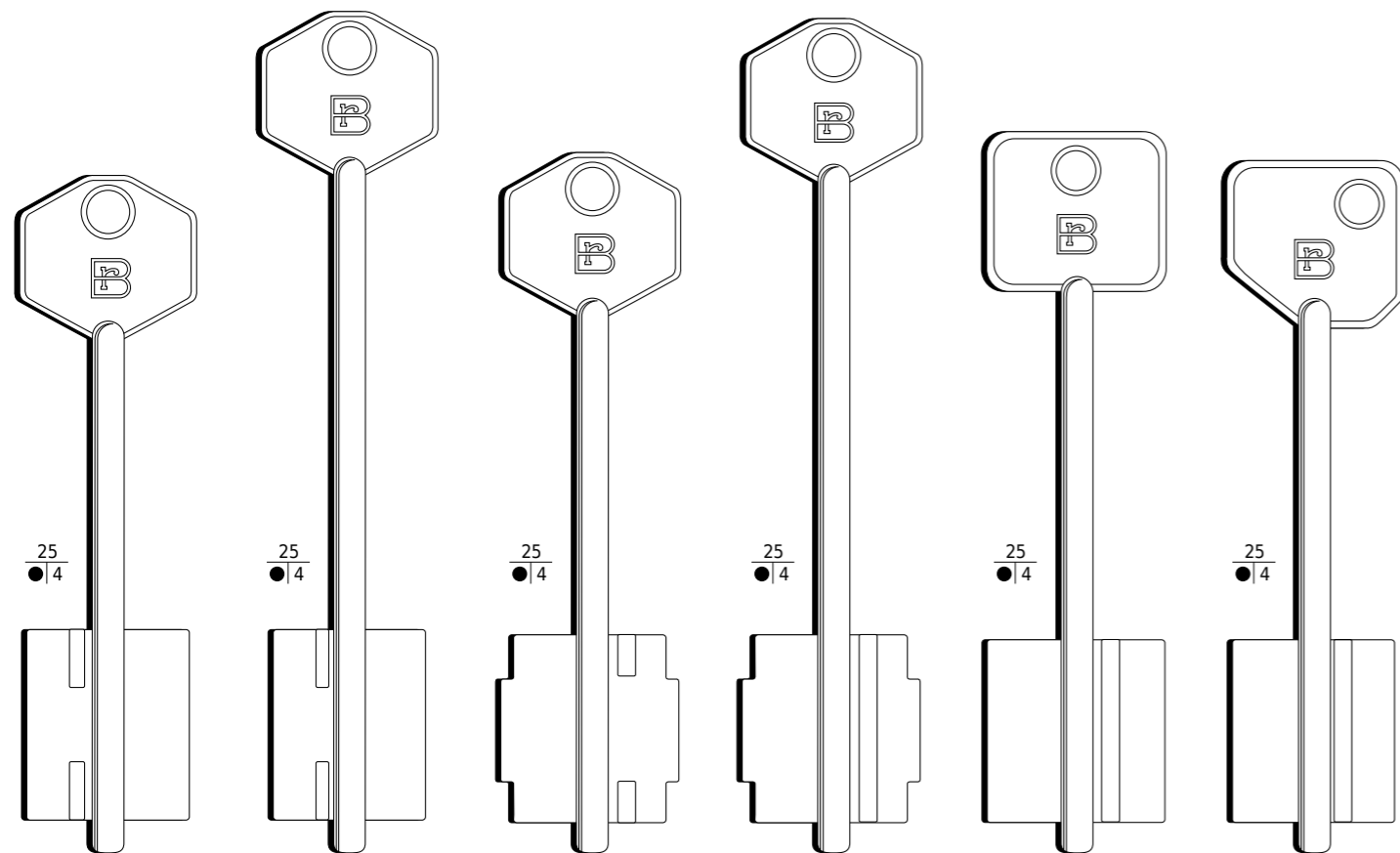

PO7



S. 5PT1
E. 2PN8

PO4



S. PLL/5PT7
E. 2PN7
K. 2PO7

PO14



S. 5PT12
E. 2PN16
K. 14PO

PO12



S. 5PT10
E. 2PN11

PO19



S. 5PT20
E. 2PN15
K. 1PO2

PO20



S. 5PT22
E. 2PN17
K. 12PO

PO8



S. 5PT2
E. 2PN8R
K. 2PO2

PATRONE

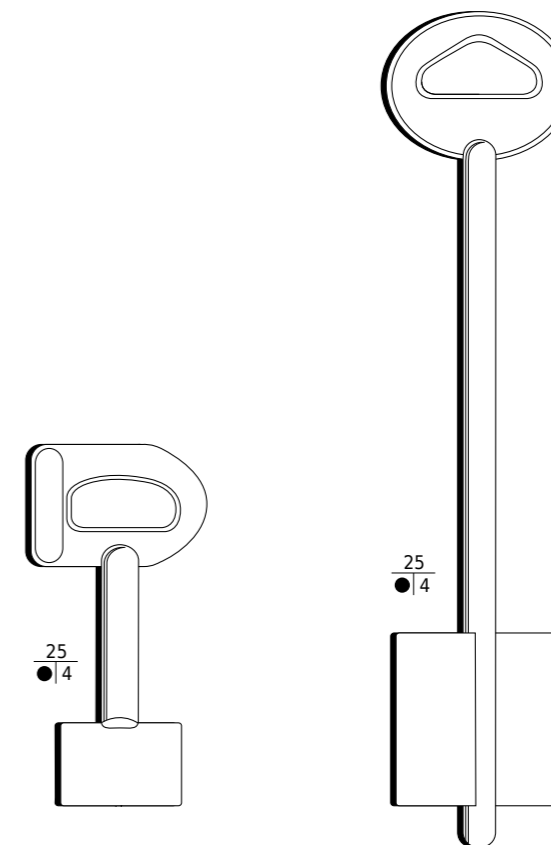

PTP3



S. IPP
E. 1PT2

PT2



S. PTL
E. 2PT3

PREFER

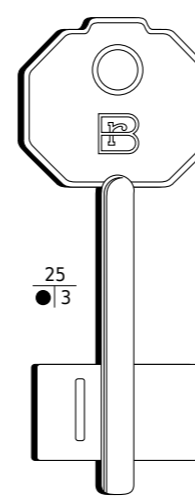

PR4



S. 5PF1
E. 1PR3
K. 2PR3

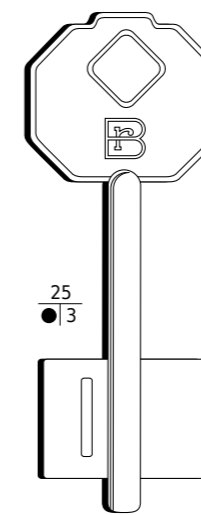

PR6



S. 5PF3
E. 1PR4
K. 2PR4

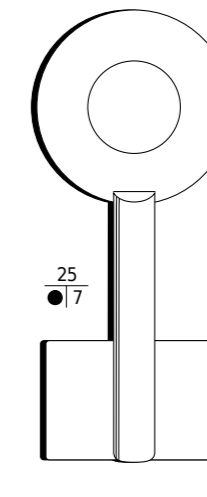

PFF



S. PFF
E. 2PR1

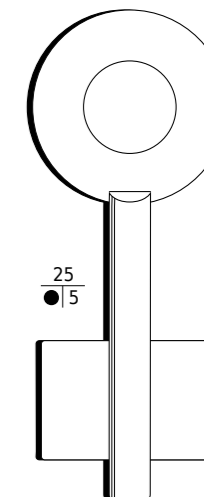

PFM



S. PFM
E. 1PR2

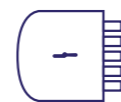

SAB

SAFE-MIA

SECUREMME

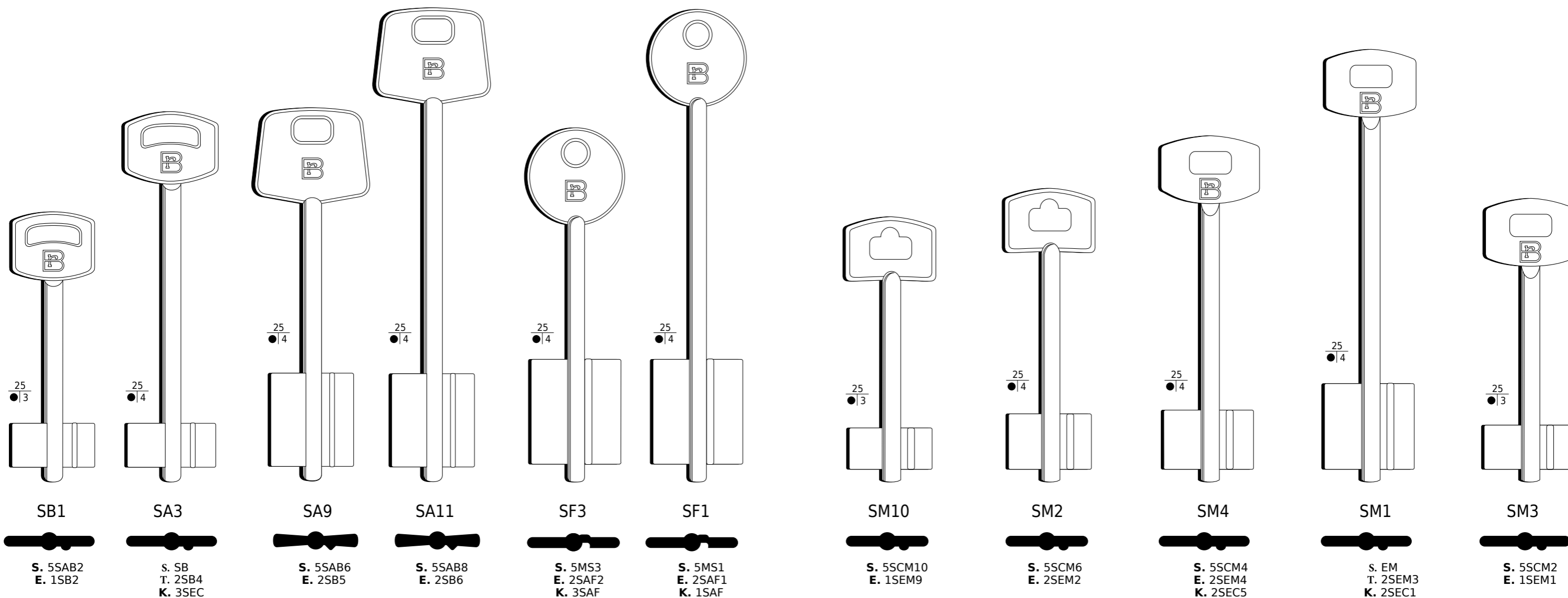

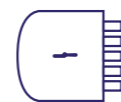

SECUREMME

SERMEC

SIAS

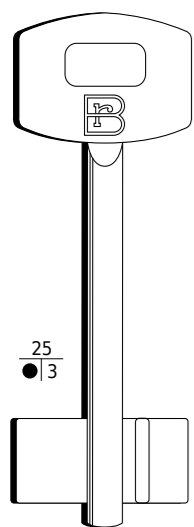

SM6



S. S
E. 1SEM1
K. 5SEC

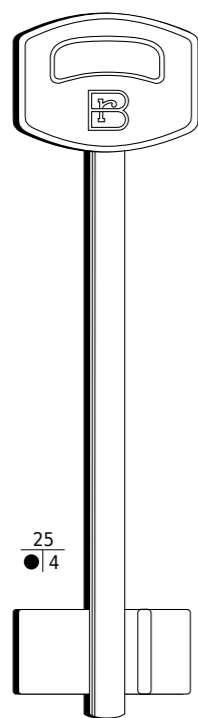

SA3



S. SB
E. 2SB4
K. 3SEC

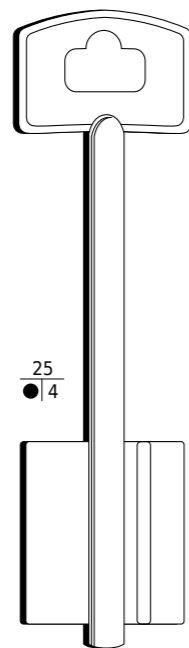

SM7



S. 5SCM8
E. 2SEM8
K. 2SEC8

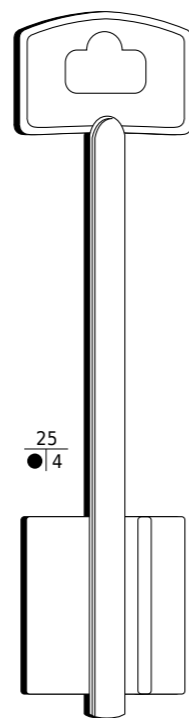

SM8



S. 5SCM14
E. 2SEM11

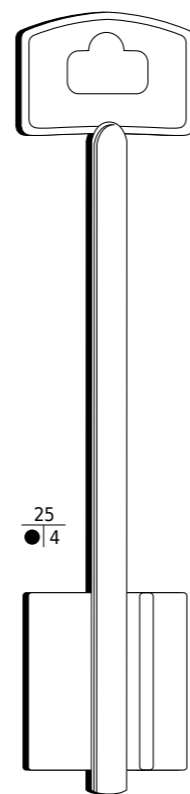

SM9



S. 5SCM12
E. 2SEM10
K. 2SEC3

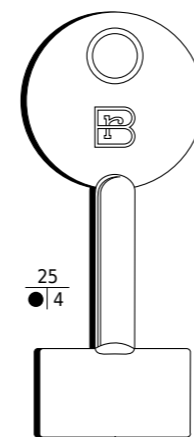

SRP1



S. SRP
T. 1SER1

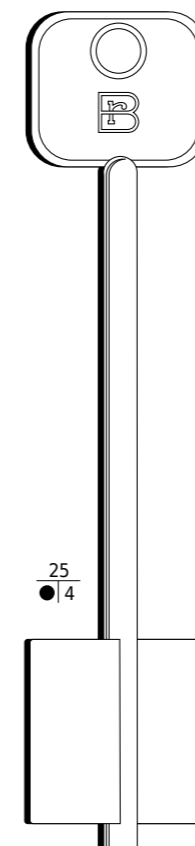

SR4



S. 5SR2
E. 2SER3

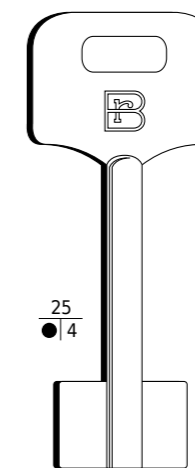

SIP3



S. 5SAS1
E. 1SAS1

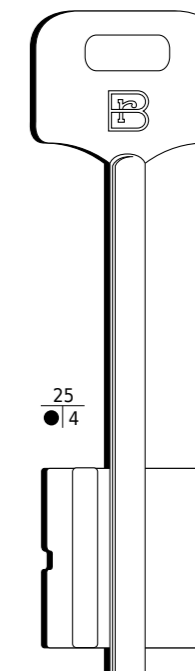

SI2



S. 5SAS3
E. 2SAS3

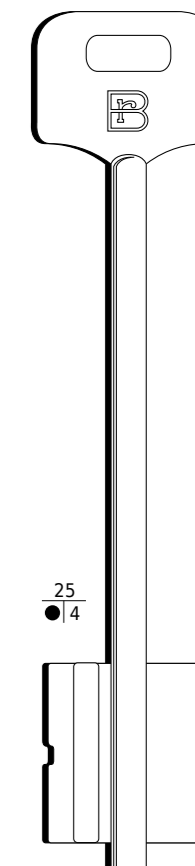

SI1



S. 5SAS5
E. 2SAS5
K. 2SIA5

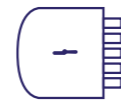

TESIO

TO

YALE

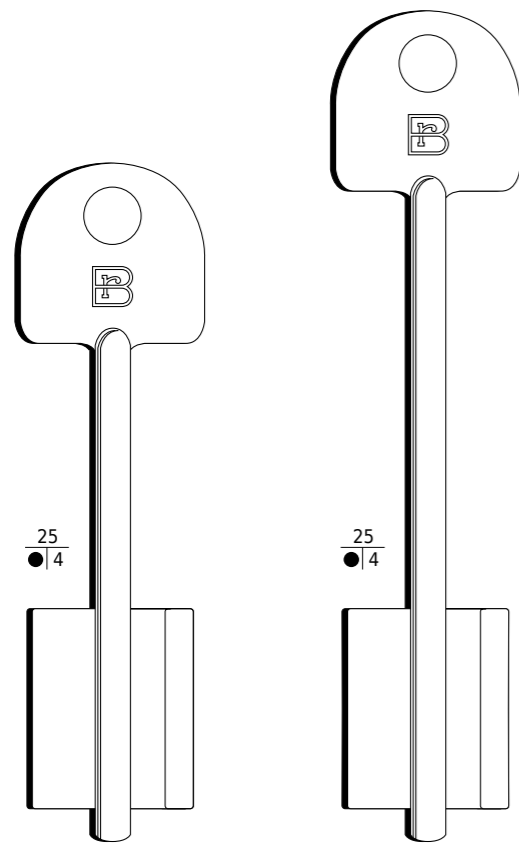

$\frac{25}{\bullet 4}$

$\frac{25}{\bullet 4}$

TE1

TE3



S. 5TS11
E. 2TS1
K. 2TE1

S. 5TS13
E. 2TS2
K. 2TE3

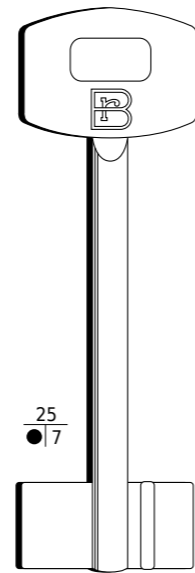

$\frac{25}{\bullet 7}$

SB21



S. SF
E. 2S3F

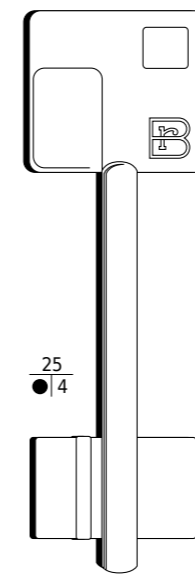

$\frac{25}{\bullet 4}$

YL13



S. 5YA9
E. 2Y19R

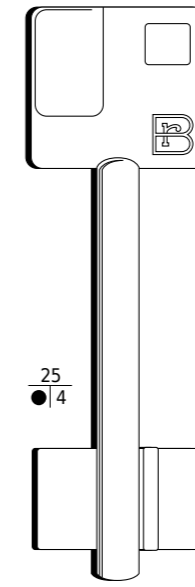

$\frac{25}{\bullet 4}$

YL14



S. 5YA10
E. 2Y19

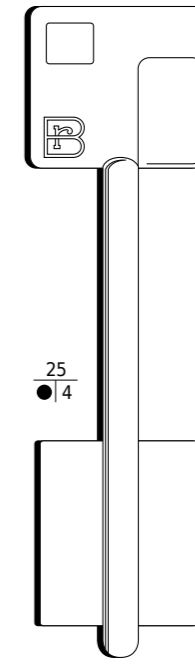

$\frac{25}{\bullet 4}$

YL5



S. 5YA6

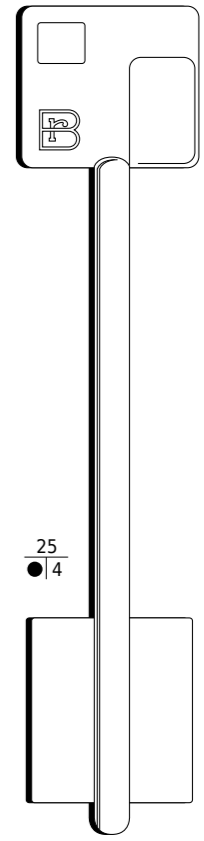

$\frac{25}{\bullet 4}$

YL7



S. 5YA8
E. 2Y15

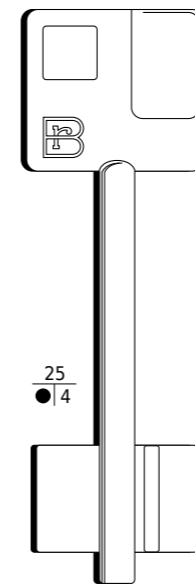

$\frac{25}{\bullet 4}$

YL9



S. 5YA4
E. 1Y13

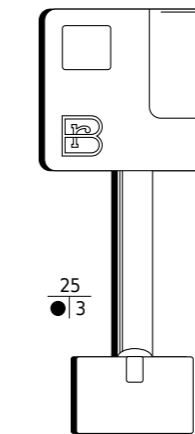

$\frac{25}{\bullet 3}$

YLP3



S. 5YA1
E. 1Y12
K. 2YE1

GAS

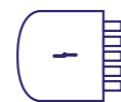

CHIAVI DOPPIA MAPPA
DOUBLE BIT
DOUBLE PANNETON
DOPPELBART
DOBLE MAPA

MAZZETTA

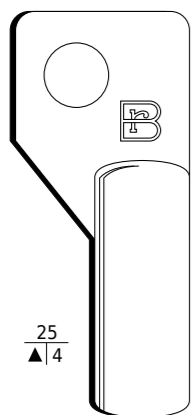

25
▲|4

TAQ
7

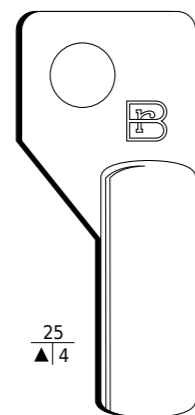

25
▲|4

TAT

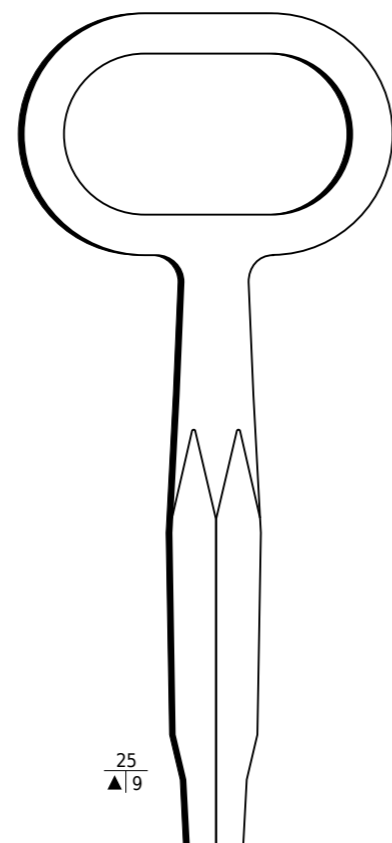

25
▲|9

TAV

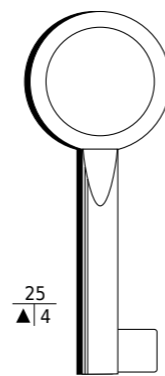

25
▲|4

CAF

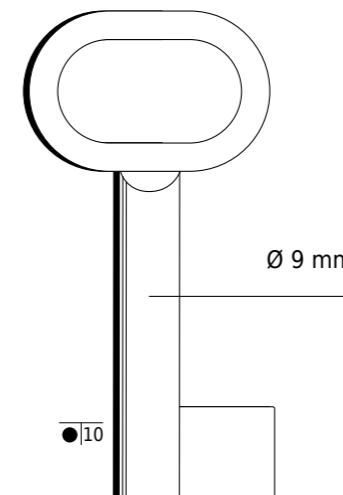

Ø 9 mm

●|10

CM3

Ø 6 mm

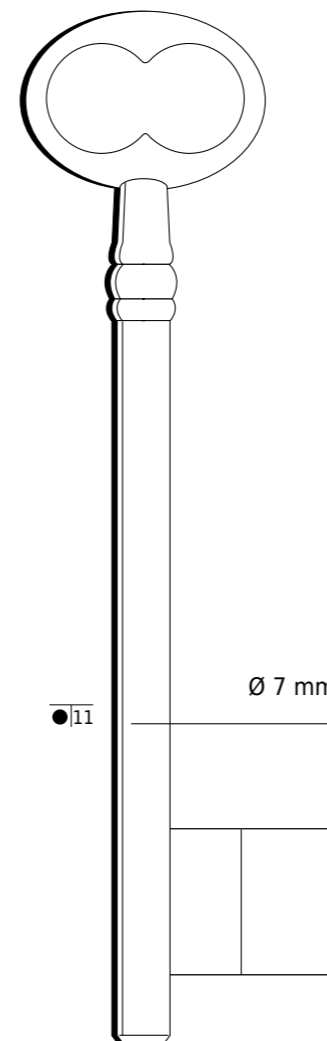

●|11

Ø 7 mm

CM1

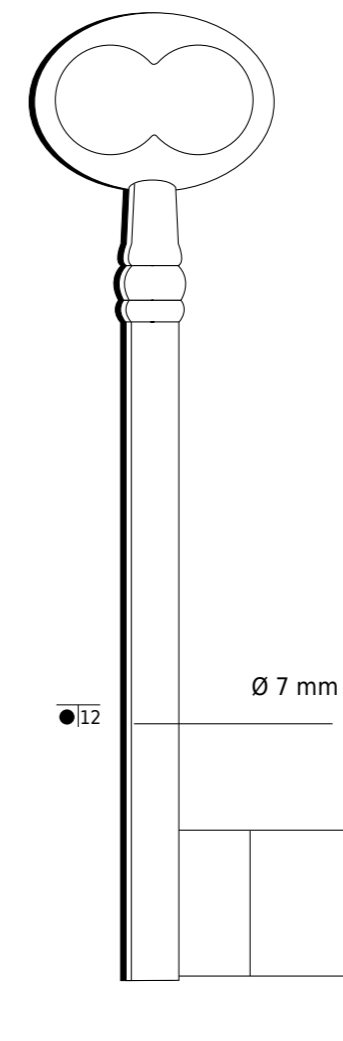

●|12

Ø 7 mm

CM2

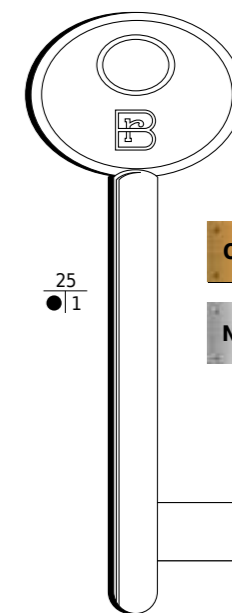

25
●|1

MP18



OTTONATO

NICHELATO

K. PAT9

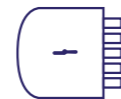

PASSEPARTOUT

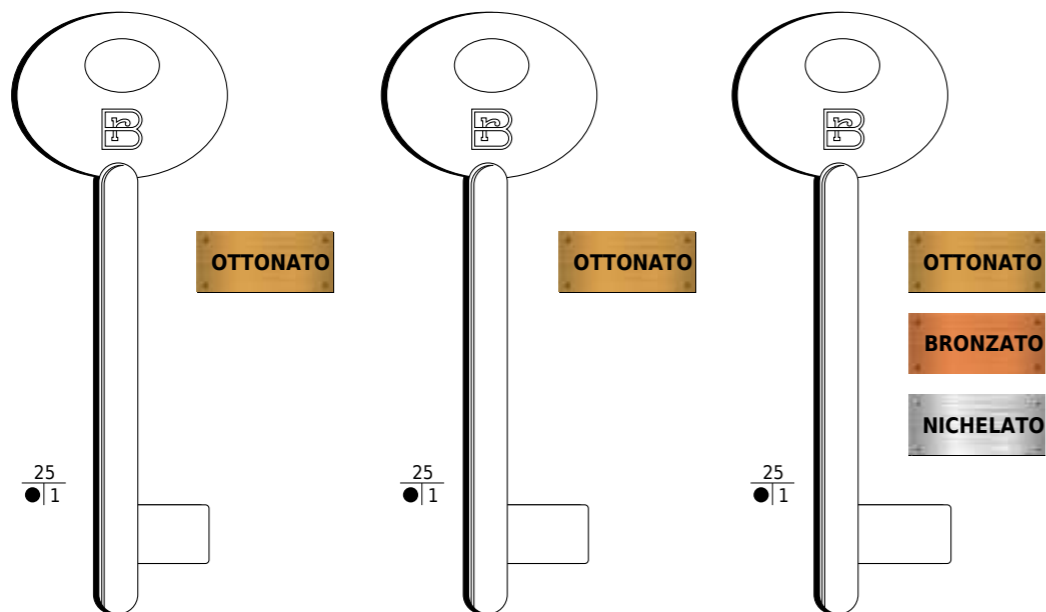

PMP15



14,6 mm
S. 5010
E. PP27P
K. PAT3

PMP16



16,5 mm
S. 5011
E. PP27M
K. PAT2

PMP18



18 mm
S. 5012
E. PP27G
K. PAT1

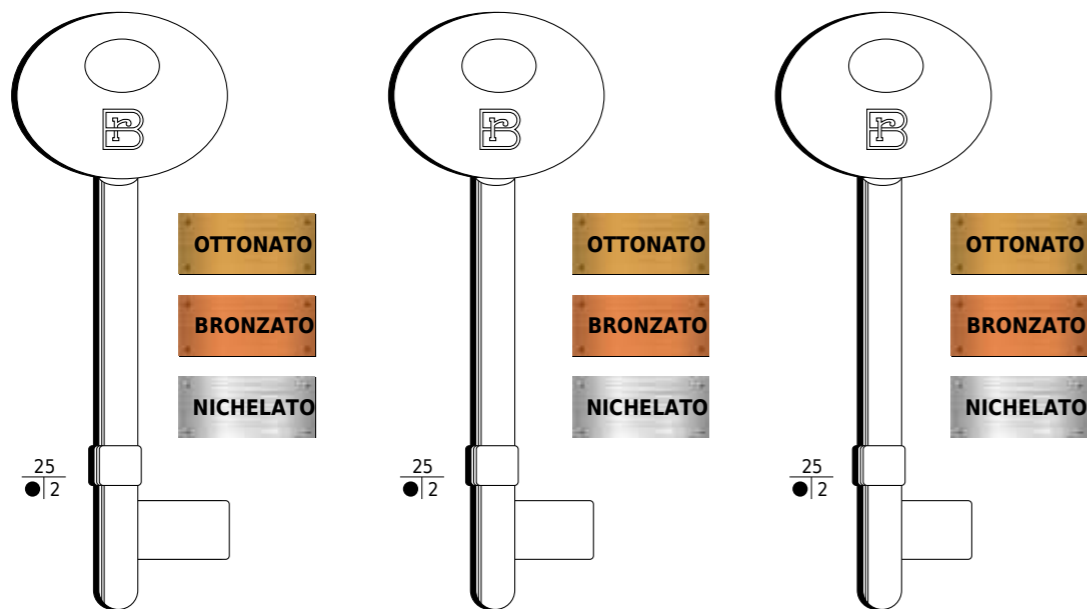

UPP1



18 mm
E. PP27GAB

UPP2



16,5 mm
E. PP27MAB

UPP3



14,6 mm

PATENT

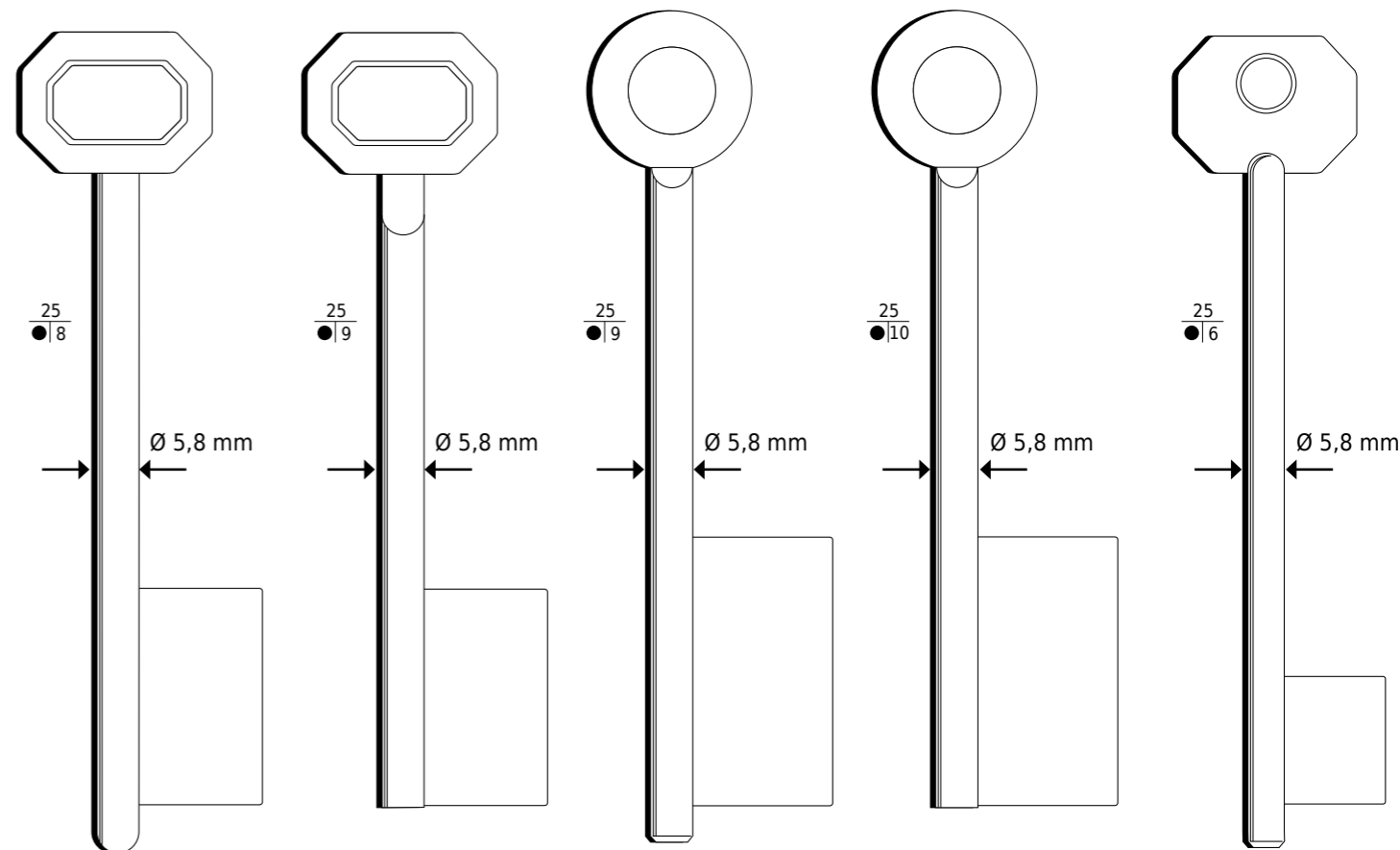

PS30



PSF30



Ø 3,6 mm

PS40



PSF40



Ø 3,6 mm

PSB



PATENT

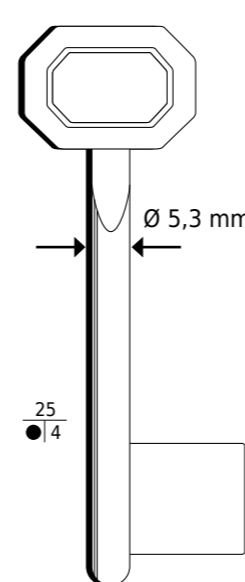

PS15



NEMEF

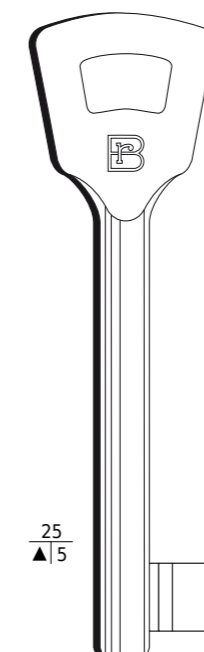

25/5



NML1 NML2 NML3 NML4 NML5 NML6
S. NFHL1 S. NFHL2 S. NFHL3 S. NFHL4 S. NFHL5 S. NFHL6
E. 46NF1L E. 46NF2L E. 46NF3L E. 46NF4L E. 46NF5L E. 46NF6L
K. NF1 K. NF2 K. NF3 K. NF4 K. NF5 K. NF6



NML7 NML8 NML9 NML10
S. NFHL7 S. NFHL8 S. NFHL9 S. NFHL10
E. 46NF7L E. 46NF8L E. 46NF9L E. 46NF10L
K. NF7 K. NF8 K. NF9 K. NF10



CIAT
SERVIZIO
AUTOMOTIVE TECHNOLOGY



CAWI

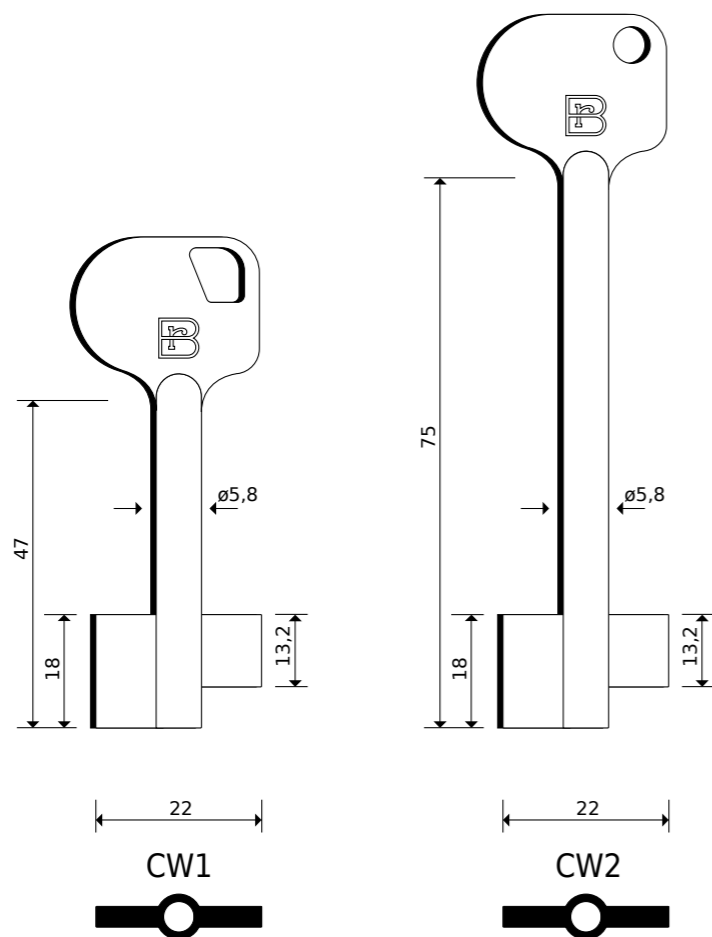

GENERICHE

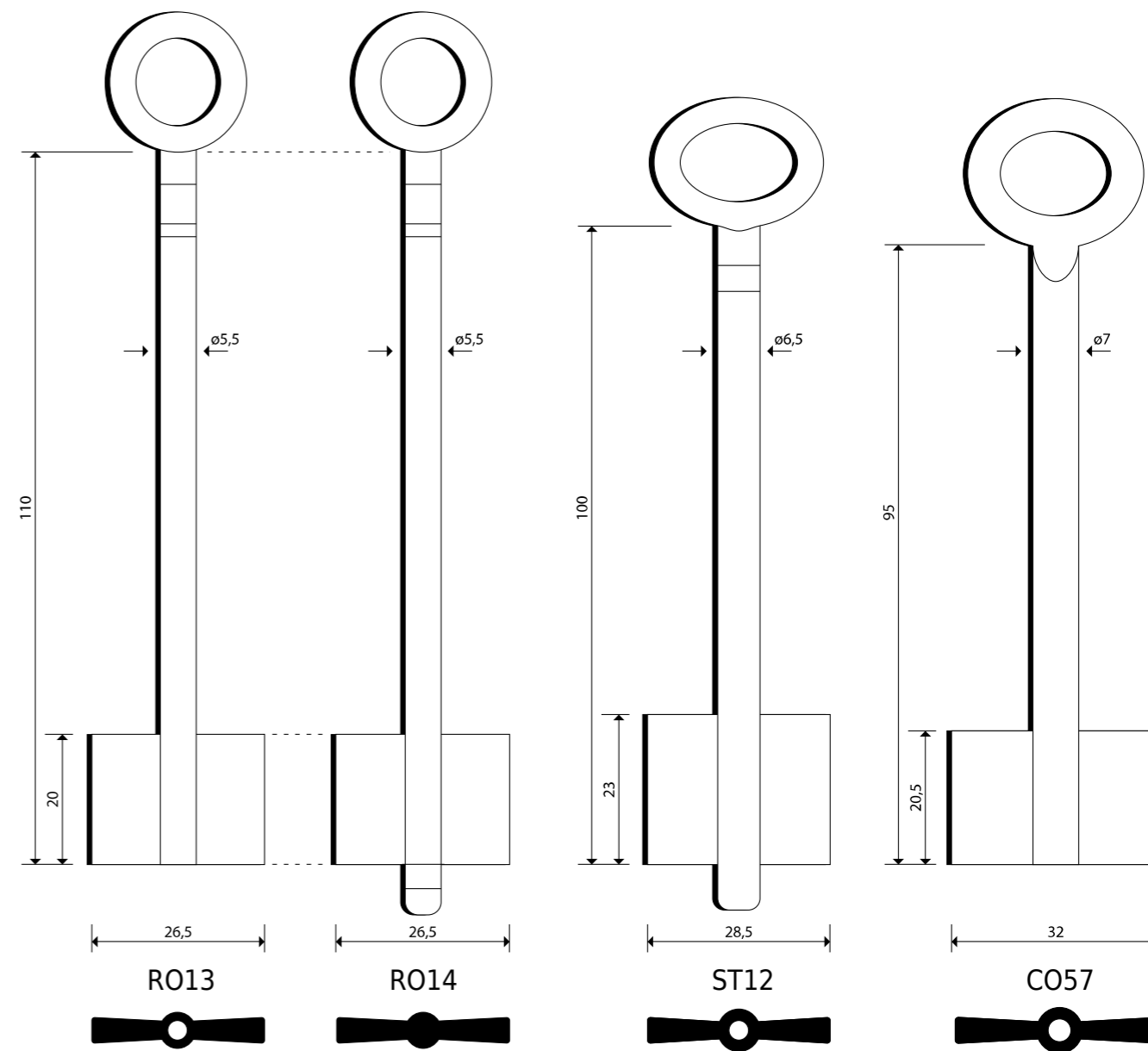

GENERICHE

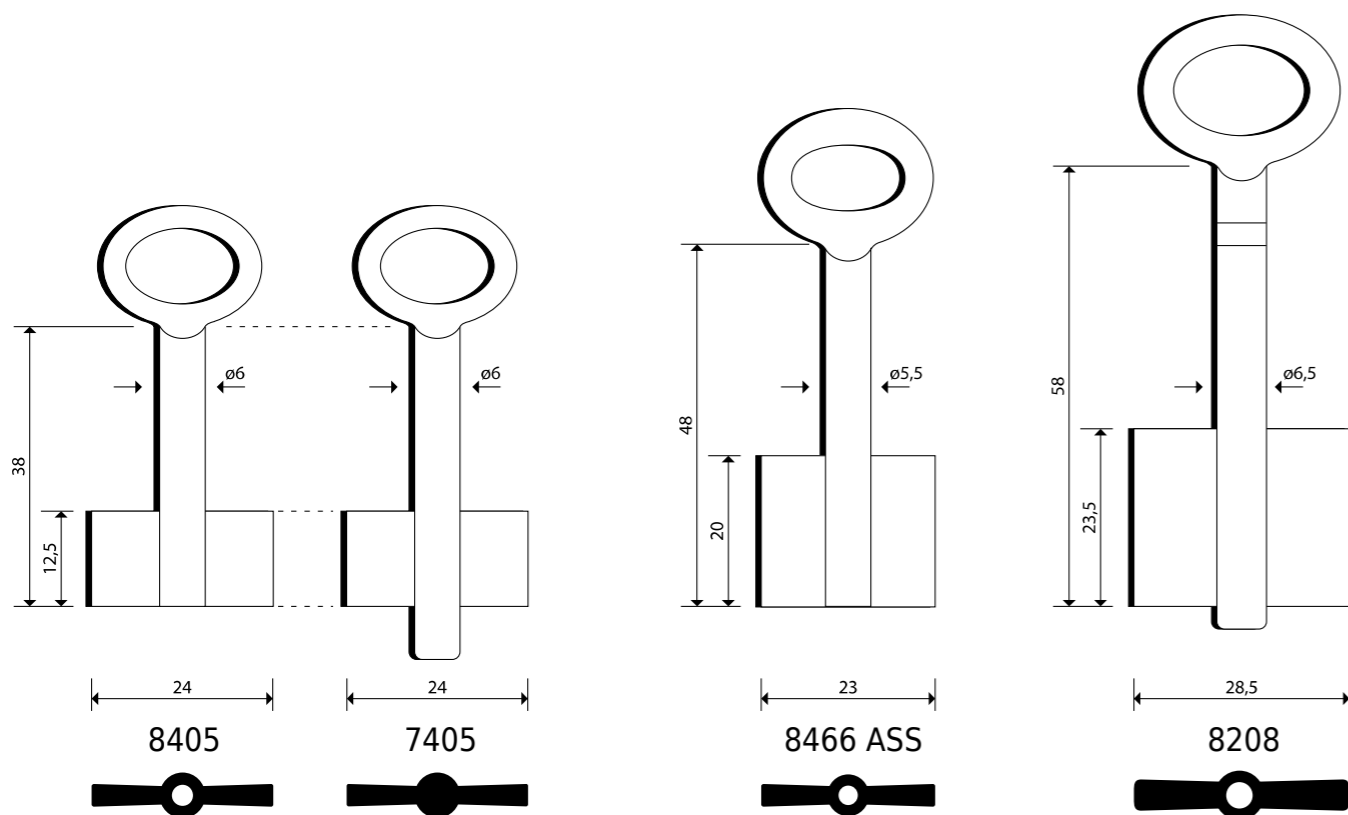



LIPS VAGO - CONFORTI

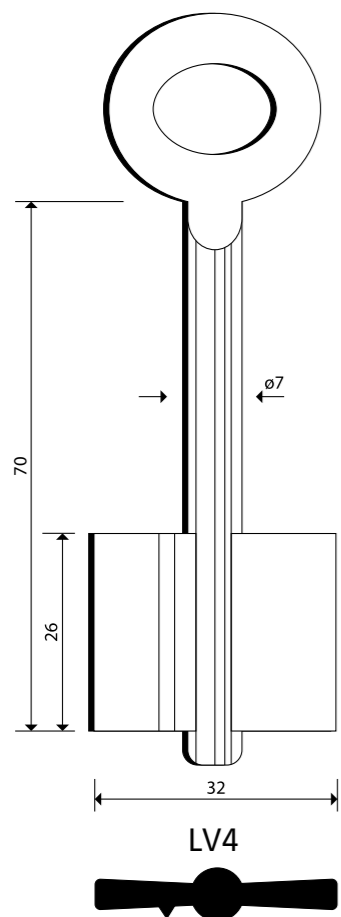

LV4

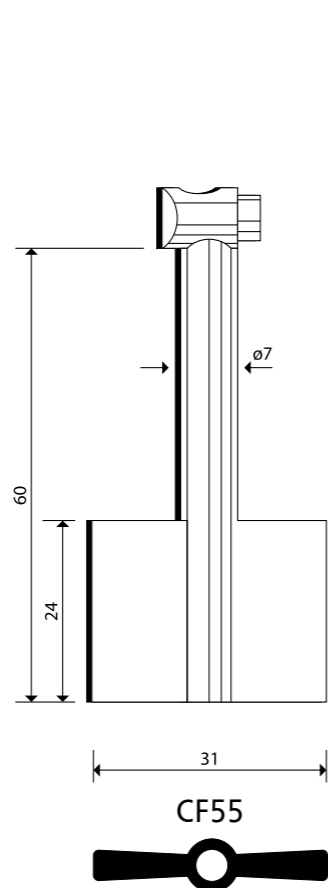

CF55

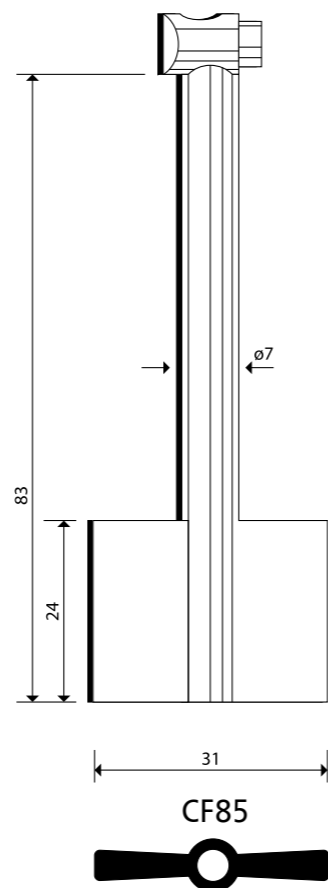

CF85

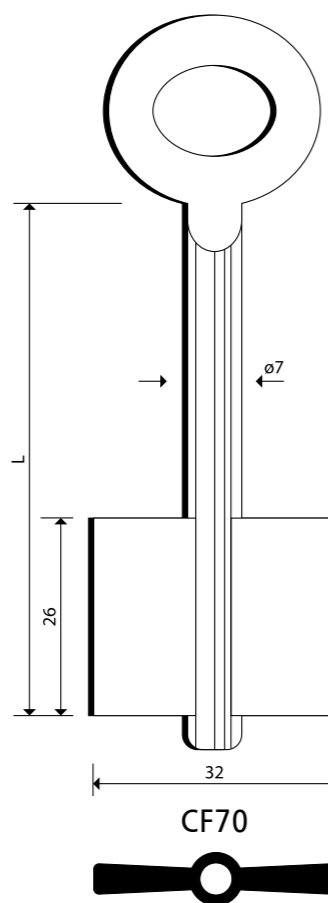

CF70

| CODICE | L |
|--------|--------|
| CF 70 | mm 70 |
| CF 100 | mm 100 |
| CF 120 | mm 120 |
| CF 140 | mm 140 |
| CF 160 | mm 160 |
| CF 180 | mm 180 |
| CF 200 | mm 200 |

FUMEO

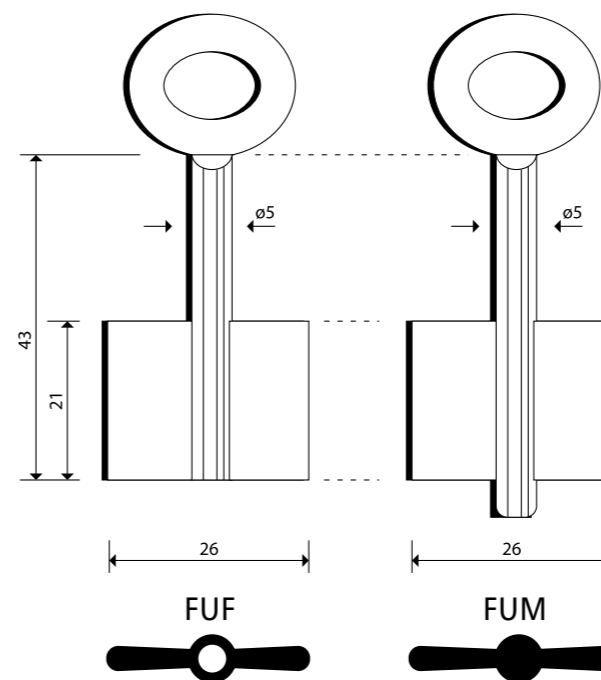

FUF

FUM

SELLA & WALTZ

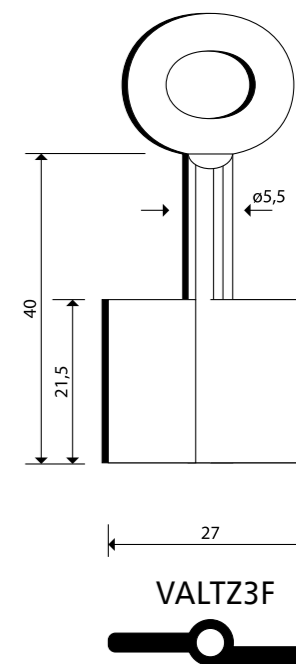

VALTZ3F

FIAMCA

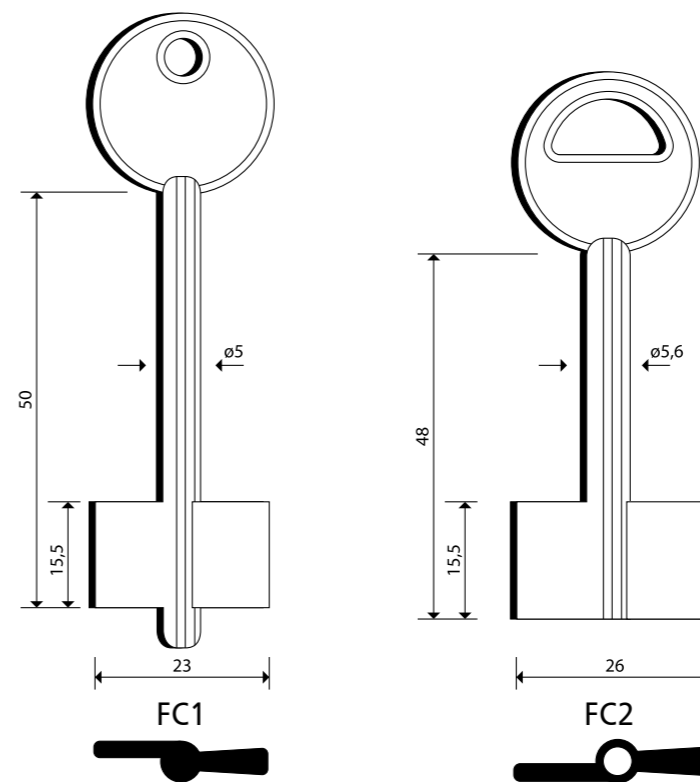

FC1

FC2

FICHET

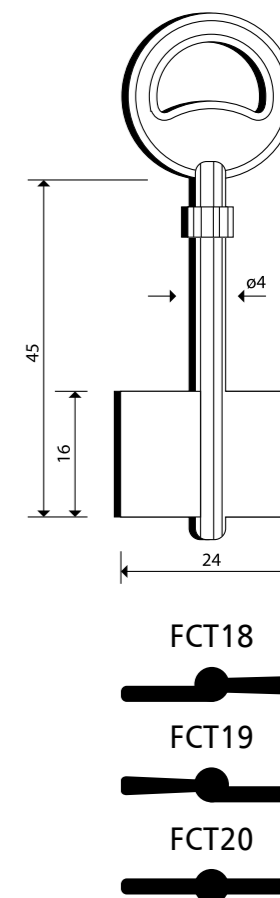

FCT18

FCT19

FCT20



PARMA

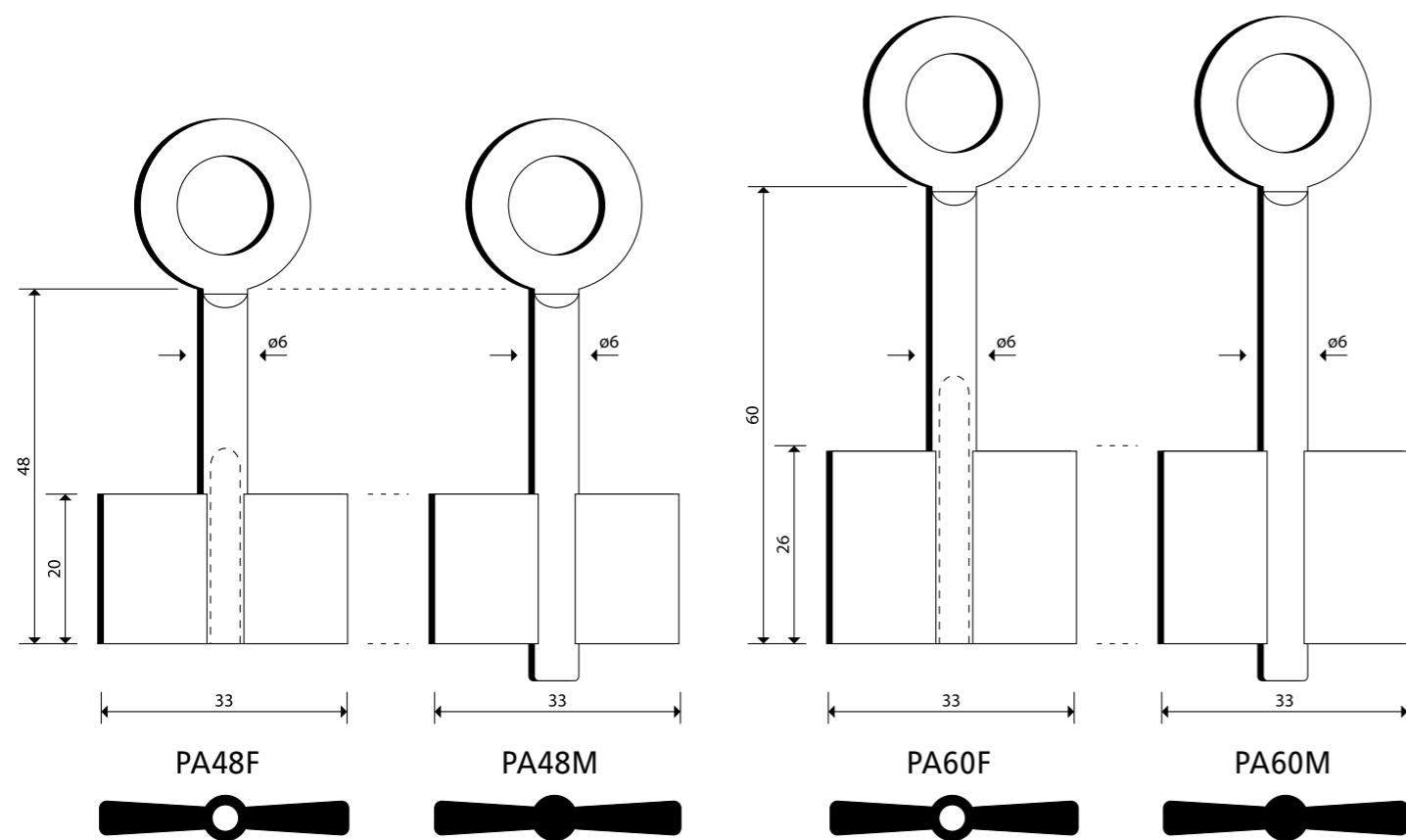

PARMA

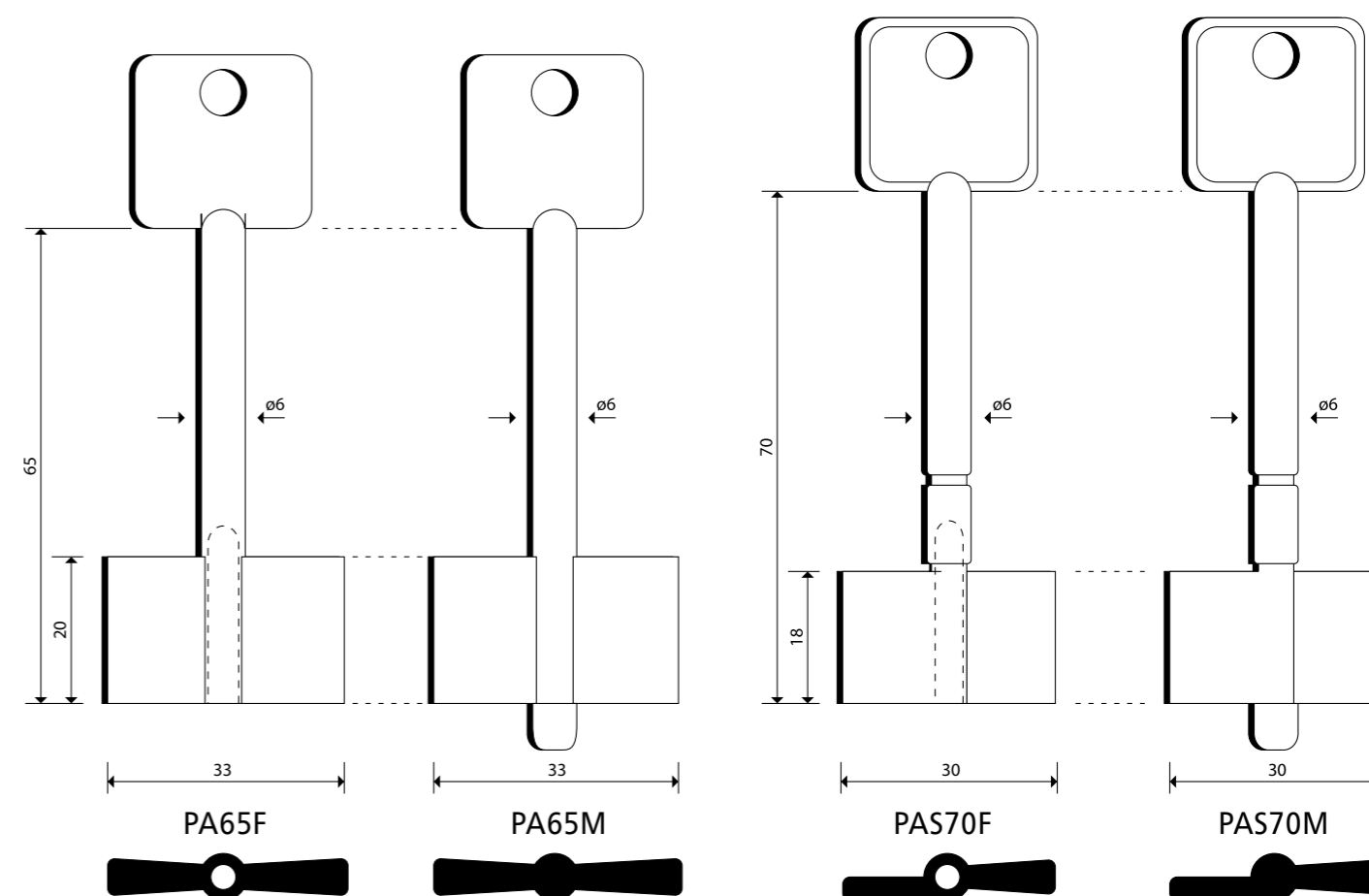

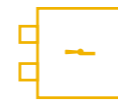

PARMA

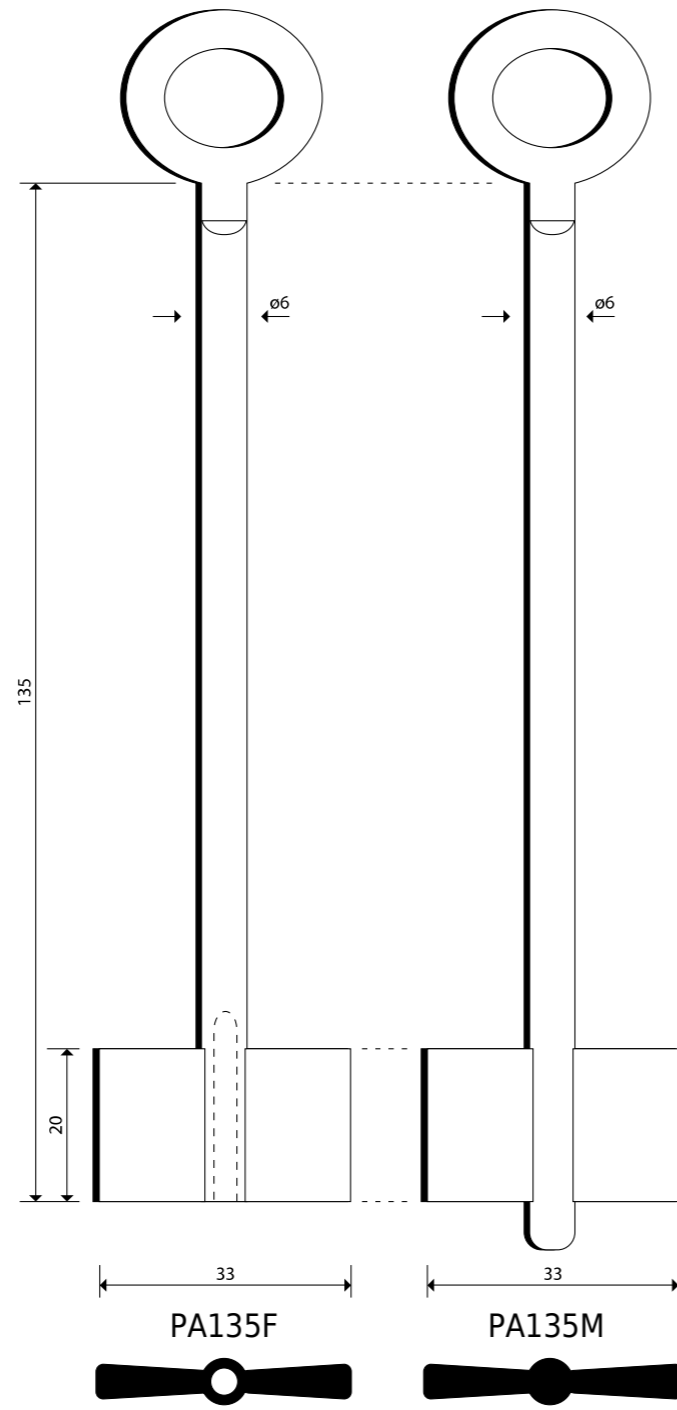
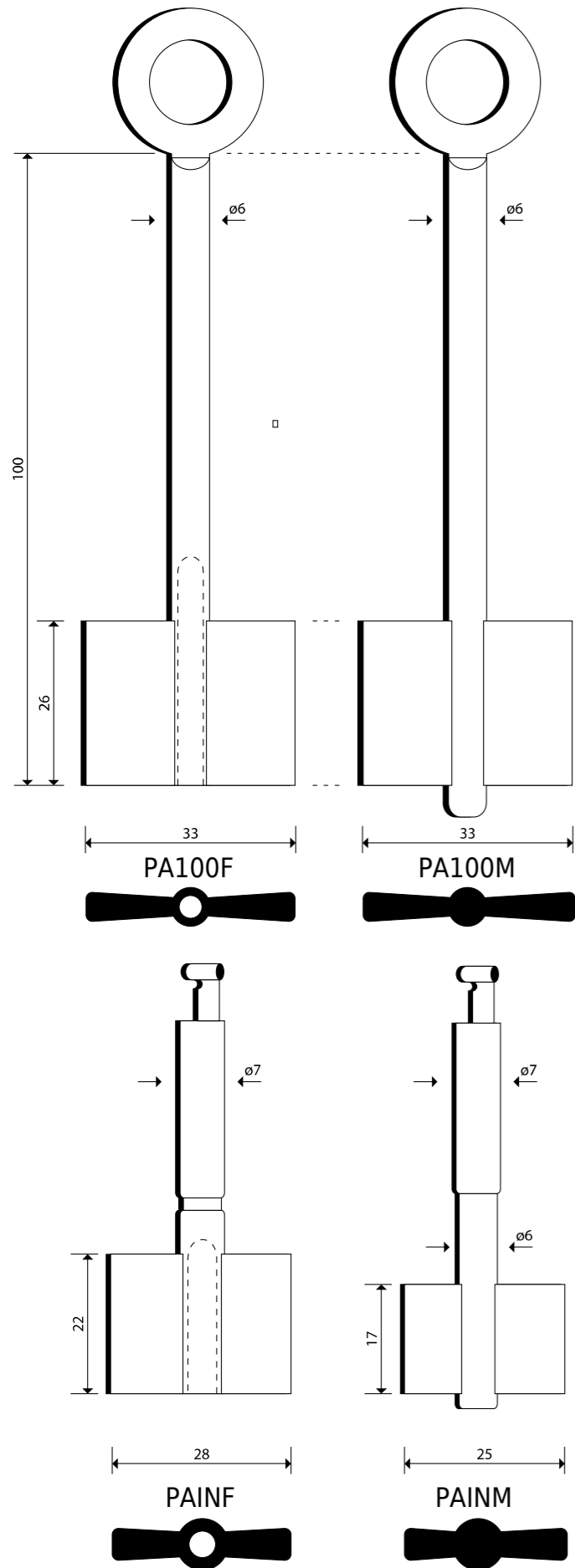

MAUER

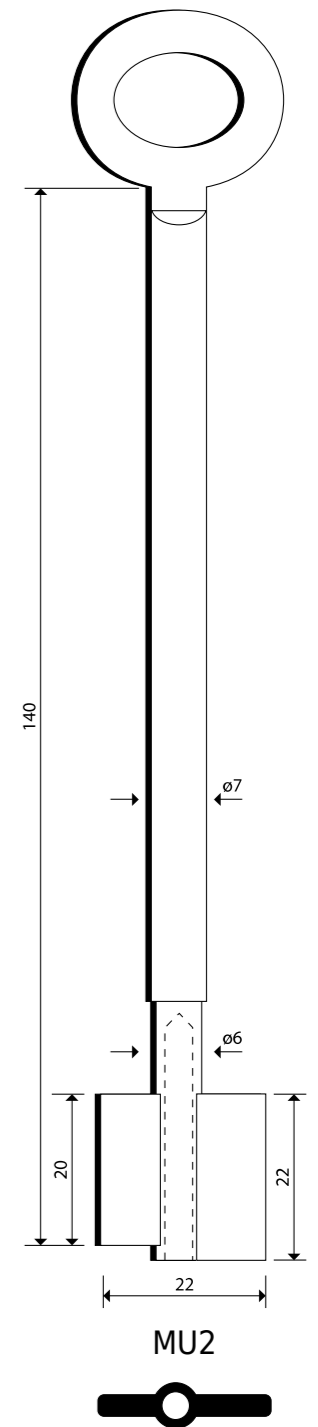
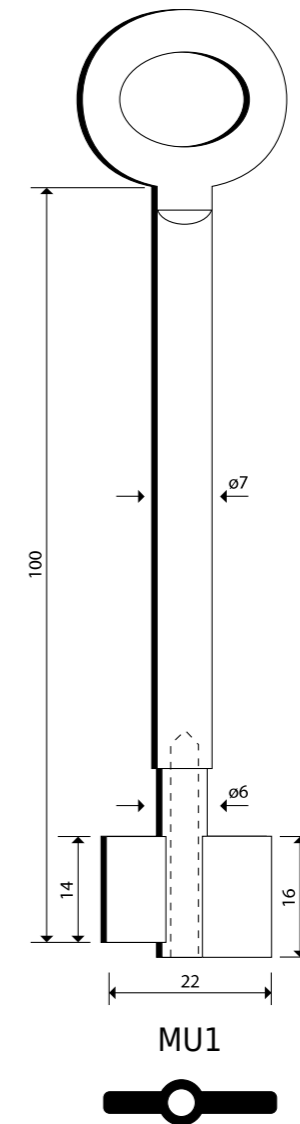
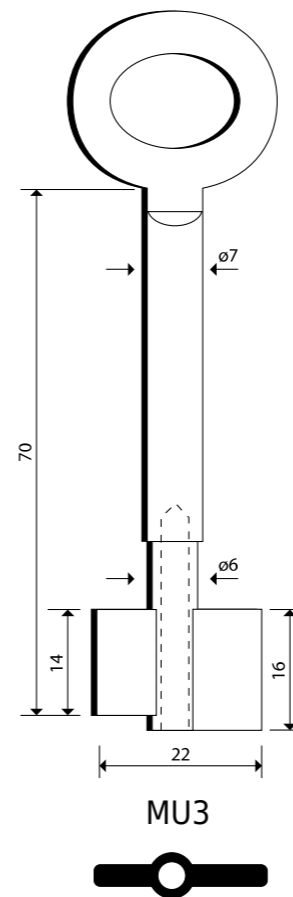
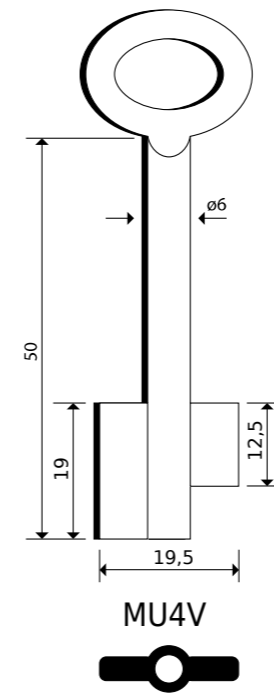

FAS

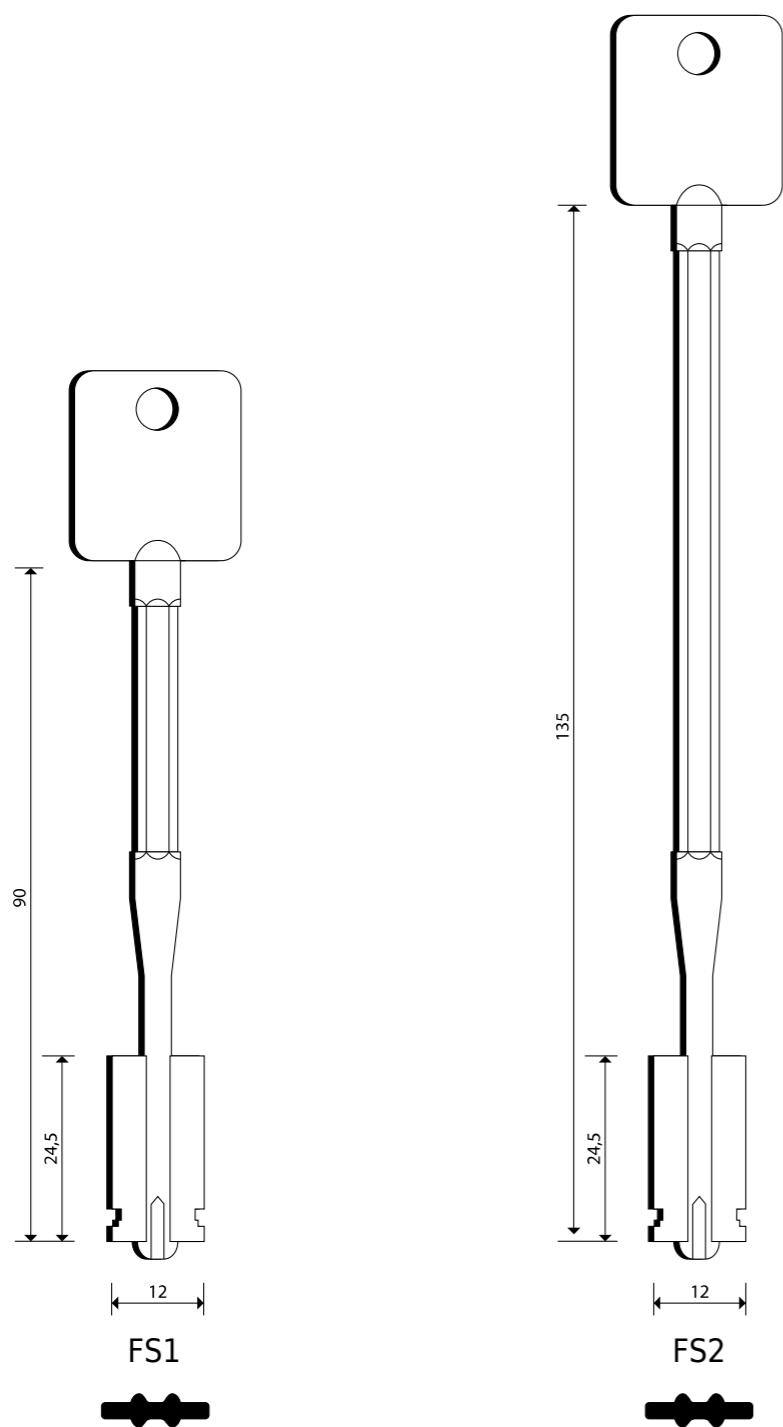

MAPPE CON ASTA

MISURE ASTE

| | |
|------|--------|
| UC1 | 50 mm |
| UC2 | 70 mm |
| UC3 | 90 mm |
| UC4 | 110 mm |
| UC5 | 130 mm |
| UC6 | 150 mm |
| UC7 | 200 mm |
| UC8 | 250 mm |
| UC9 | 300 mm |
| UC10 | 350 mm |
| UC11 | 400 mm |
| UC12 | 450 mm |
| UC13 | 500 mm |
| UC14 | 550 mm |
| UC15 | 850 mm |

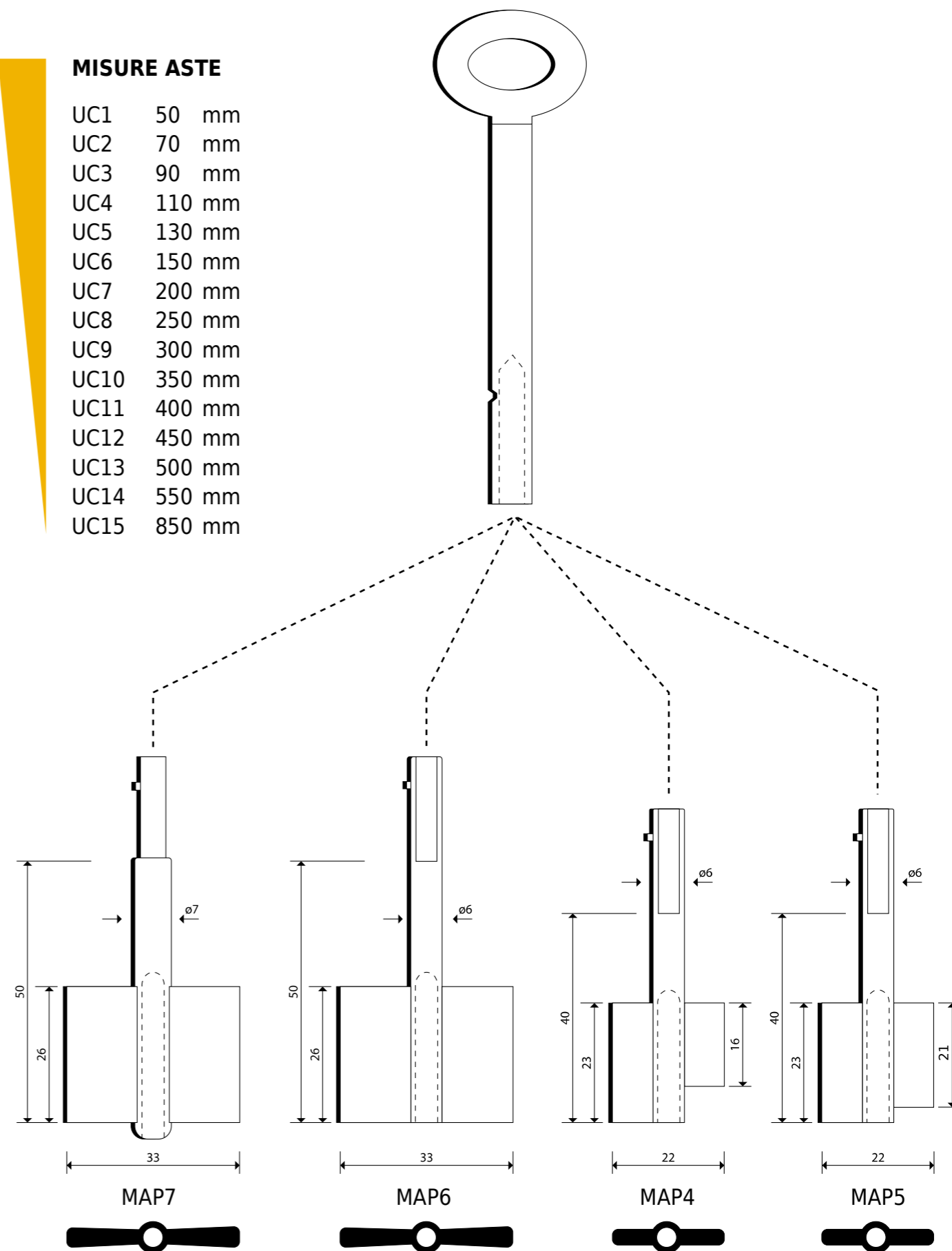



CIAT Service S.a.s

Via Vittorio Emanuele III 102/104
80027 Frattamaggiore (Na) Italia

P.iva 07583151217

S e g u i c i



www.ciat-service.it



